



FX810e

FOIL IMPRINTER

User's Manual

©2021, DTM Print GmbH. All rights reserved

For the most recent version of this manual please visit dtm-print.eu/manuals



FCC COMPLIANCE STATEMENT
FOR AMERICAN USERS

Federal Communication Commission Interference Statement

This equipment has been tested and found to comply with the limits for a Class B digital device, pursuant to Part 15 of the FCC Rules. These limits are designed to provide reasonable protection against harmful interference in a residential installation. This equipment generates, uses and can radiate radio frequency energy and, if not installed and used in accordance with the instructions, may cause harmful interference to radio communications. However, there is no guarantee that interference will not occur in a particular installation. If this equipment does cause harmful interference to radio or television reception, which can be determined by turning the equipment off and on, the user is encouraged to try to correct the interference by one of the following measures:

Reorient or relocate the receiving antenna.

Increase the separation between the equipment and receiver.

Connect the equipment into an outlet on a circuit different from that to which the receiver is connected.

Consult the dealer or an experienced radio/TV technician for help.

This device complies with Part 15 of the FCC Rules. Operation is subject to the following two conditions:

(1) This device may not cause harmful interference, and (2) this device must accept any interference received, including interference that may cause undesired operation.

FCC Caution: Any changes or modifications not expressly approved by the party responsible for compliance could void the user's authority to operate this equipment.

TO WHICH THIS DECLARATION RELATES
IS IN CONFORMITY WITH THE FOLLOWING STANDARDS

FCC CFR Title 47 Part 15 Subpart B:2015 Class B,CISPR 22:2008 ANSI C63.4: 2014 ICES-003 Issue 6:2016, Class B IEC 60950-1:2005(Second Edition)+Am1:2009+Am2:2013

GB4943.1-2011,GB9254-2008,GB17625.1-2012

EN55024:2010+A1:2015

EN55032:2012+AC:2013,Class B

EN61000-3-2:2014

EN61000-3-3:2013

AS/NZS CISPR 22:2009+A1:2010

SAFETY INSTRUCTIONS

Please read the following instructions carefully.

- Keep the equipment away from humidity.
- Before you connect the equipment to the power outlet, please check the voltage of the power source.
- Make sure the printer is off before plugging the power connector into the power jack.
- It is recommended that you connect the printer to a surge protector to prevent possible transient overvoltage damage.
- Be careful not to get liquid on the equipment to avoid electrical shock.
- For safety and warranty reasons, **ONLY** qualified service personnel should open the equipment.
- Do not repair or adjust energized equipment under any circumstances.

CAUTION

- Danger of explosion if battery is incorrectly replaced. Replace only with the equivalent type recommended by the manufacturer.
- Dispose of used batteries according to the manufacturer's instructions.
- Only use with designated power supply adapter model.
- Changes or modifications not expressly approved by the party responsible for compliance could void the user's authority to operate the equipment.

Specifications are subject to change without notice

Printer Compliance Insert



Note: This equipment may be used on an IT power system.

For Users in English Speaking Regions (en)



Caution: This marking indicates that the user should read all included documentation before use.

The users of this product are cautioned to use accessories and peripherals approved by manufacturing company. The use of accessories other than those recommended, or changes to this product that are not approved by manufacturing company, may void the compliance of this product and may result in the loss of the user's authority to operate the equipment.



Caution: For power supply, use manufacturing company. No user-serviceable parts.

FCC Digital Emissions Compliance

This equipment has been tested and found to comply with the limits for a CLASS A digital device, pursuant to Part 15 of the FCC Rules. These limits are designed to provide reasonable protection against harmful interference when the equipment is operated in a commercial environment. This equipment generates, uses, and can radiate radio frequency energy and, if not installed and used in accordance with the instructions, may cause harmful interference to radio communications. Operation of this equipment in a residential area is likely to cause harmful interference in which case the user will be required to correct the interference at own expense.

Canadian Digital Apparatus Compliance

This Class A digital apparatus meets all requirements of the Canadian Interference-Causing Equipment Regulations.

CE Marking: Refer to the Declaration of Conformity for a list of the EU Directives and Standards that this product complies with.

Für Anwender in Deutschland (de)



Vorsicht: Diese Kennzeichnung weist darauf hin, dass der Benutzer vor dem Gebrauch alle mitgelieferten Unterlagen lesen soll.

Die Benutzer dieses Produkts werden darauf hingewiesen, nur Zubehörteile und Peripheriegeräte zu verwenden, die vom Hersteller genehmigt sind. Falls nicht empfohlene Zubehörteile verwendet oder an diesem Produkt Änderungen vorgenommen werden, die nicht vom Hersteller genehmigt sind, kann dadurch die behördliche Konformität des Produkts verletzt werden und der Benutzer die Berechtigung zur Verwendung des Geräts verlieren.



Vorsicht: Nur das beigegefügte original Netzteil verwenden. Enthält keine Teile, die vom Benutzer gewartet werden können.

CE-Kennzeichnung: Die Konformitätserklärung enthält eine Liste der EU-Richtlinien und Normen, denen das Produkt entspricht.

Warnhinweis

Dies ist ein Produkt der Klasse A. In Wohnumgebungen kann dieses Produkt Funkstörungen verursachen. In diesem Fall obliegt es dem Anwender, angemessene Maßnahmen zu ergreifen.

Pour les utilisateurs canadiens et français (fr)



Attention: Ce marquage indique que l'utilisateur doit, avant l'utilisation, lire toute la documentation incluse.



Attention: Pour la source d'alimentation, utilisez fabricants. Il ne contient aucune pièce réparable par l'utilisateur.

Utilisateurs de ce produit sont avisés d'utiliser des accessoires et des périphériques approuvés par fabricants. L'utilisation d'accessoires autres que ceux recommandés ou des changements à ce produit qui ne sont pas approuvés par fabricants, peuvent annuler la conformité de ce produit et mettre fin au droit qu'a l'utilisateur d'utiliser l'équipement.

Conformité aux normes canadiennes sur les appareils numériques

Cet appareil numérique de la classe A respecte toutes les exigences du Règlement sur le matériel brouilleur du Canada.

AVERTISSEMENT: Il s'agit d'un produit de classe A. Dans un environnement domestique, ce produit pourra provoquer des interférences radio auquel cas l'utilisateur pourrait avoir à prendre de mesures adéquates.

Table of Contents



Section 1: Thermal Label Printer	6
1.1 Package Contains	6
1.2 Printer Introduction	8
Section 2: Printer Installation	10
2.1 Media Installation.....	10
2.2 Printing Mechanism Opening.....	10
2.3 Ribbon Installation	11
(4 inch Ribbon).....	11
(8 inch Ribbon).....	12
2.4 Media Specifications	14
2.4.1 Label Installation.....	16
2.5 Connection with PC.....	19
2.6 Installing The Driver	20
Section 3: Printer Operation	22
3.1 Printer Operation Interface.....	23
3.2 LCD Operation Introduction.....	23
3.3 LAN Setting Operation Instruction	28
3.4 Label size calibration and Self Test Page.....	32
3.5 Error Message	34
3.6 Connected with USB Devices.....	36
Section 4: Optional Cutter Installation	37
Section 5: Maintenance and Troubleshooting	39
5.1 Print Line Adjustment.....	39
5.2 Ribbon Tension Adjustment.....	40
5.3 Print Head Cleaning.....	40
5.4 Print Head Pressure Adjustment.....	41
5.5 Ribbon Wrinkle Adjustment	41
5.6 Cutter Error	42
5.7 Troubleshooting.....	43
Appendix - Printer Specification	44



Section 1: Getting Started

1.1 Package Contains

Please check that all of the following items are included with your printer.

- DTM FX810e or DTM FX810ec

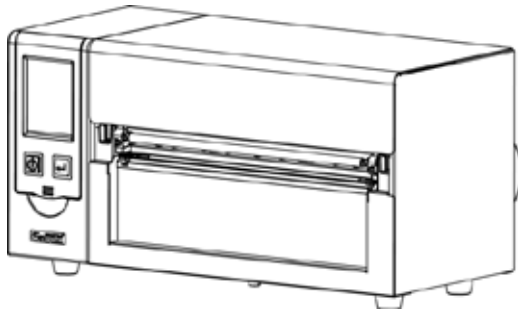

- Power Cord

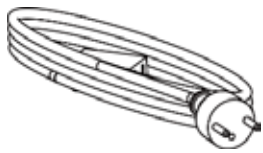

EU

or

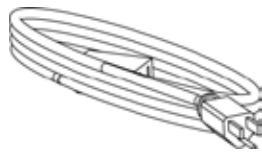

US

- USB Cable

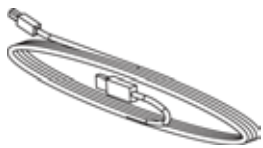

- Ribbons: gold, silver, red and blue metallic (100mm width) plus black matte (220mm width)

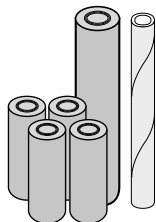

- Unwinder (please see Quickstart for setup)

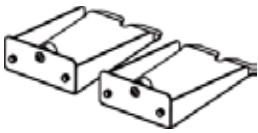
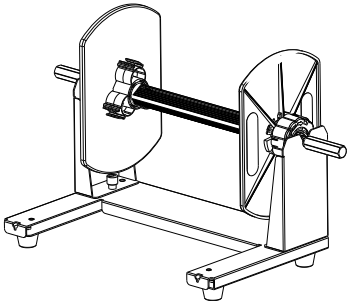

Label Roll Holder

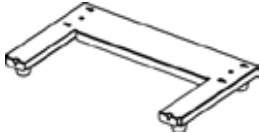

Media Holder Base



Media Shaft

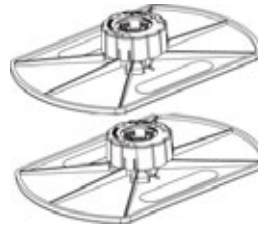

Label Roll Stopper



1.5 inch/3 inch
Ribbon Shaft

1.2 Printer Introduction

Front View

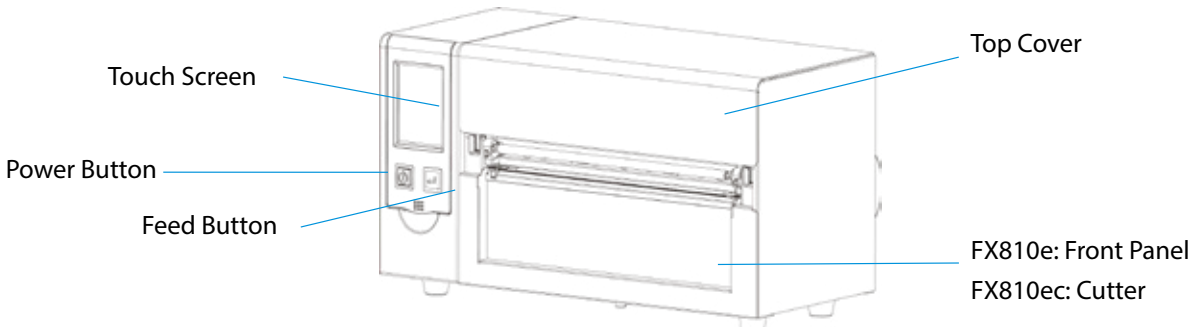

Rear View

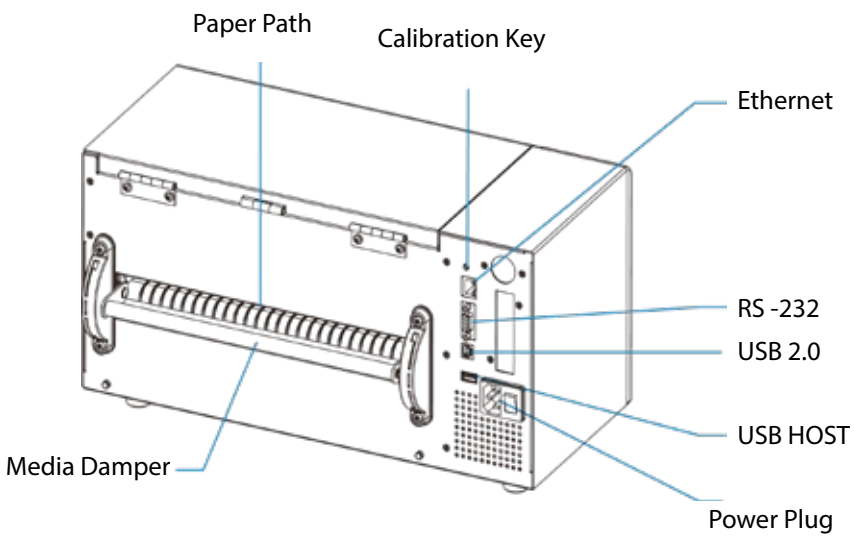

Open Top Cover

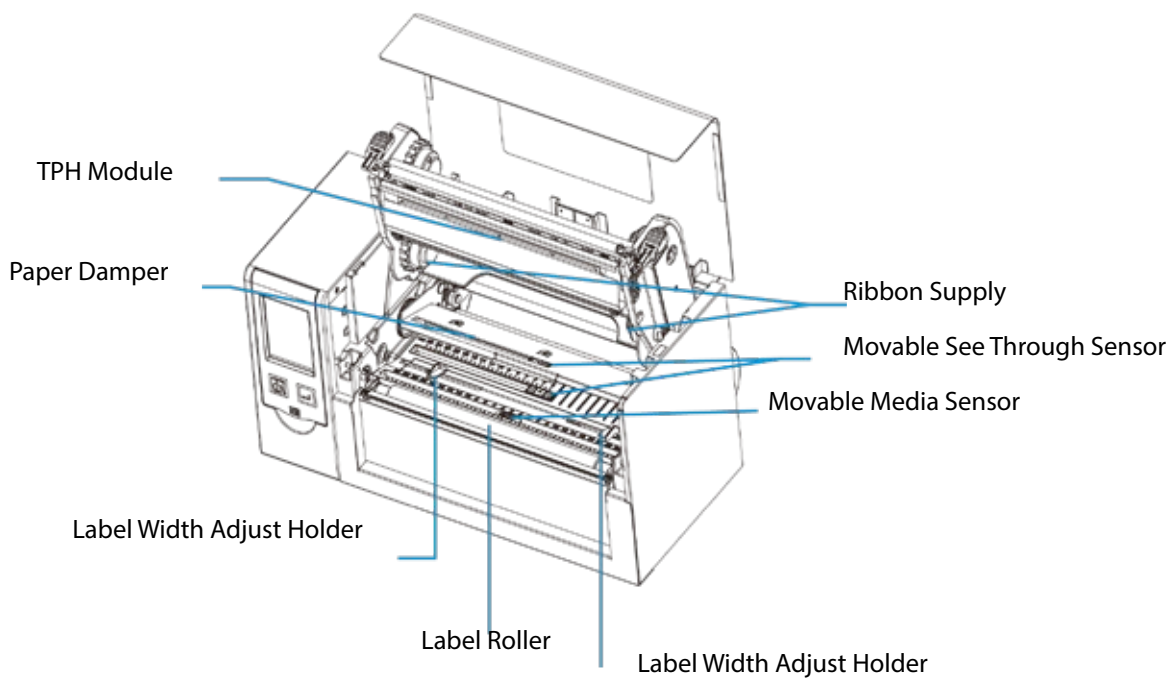
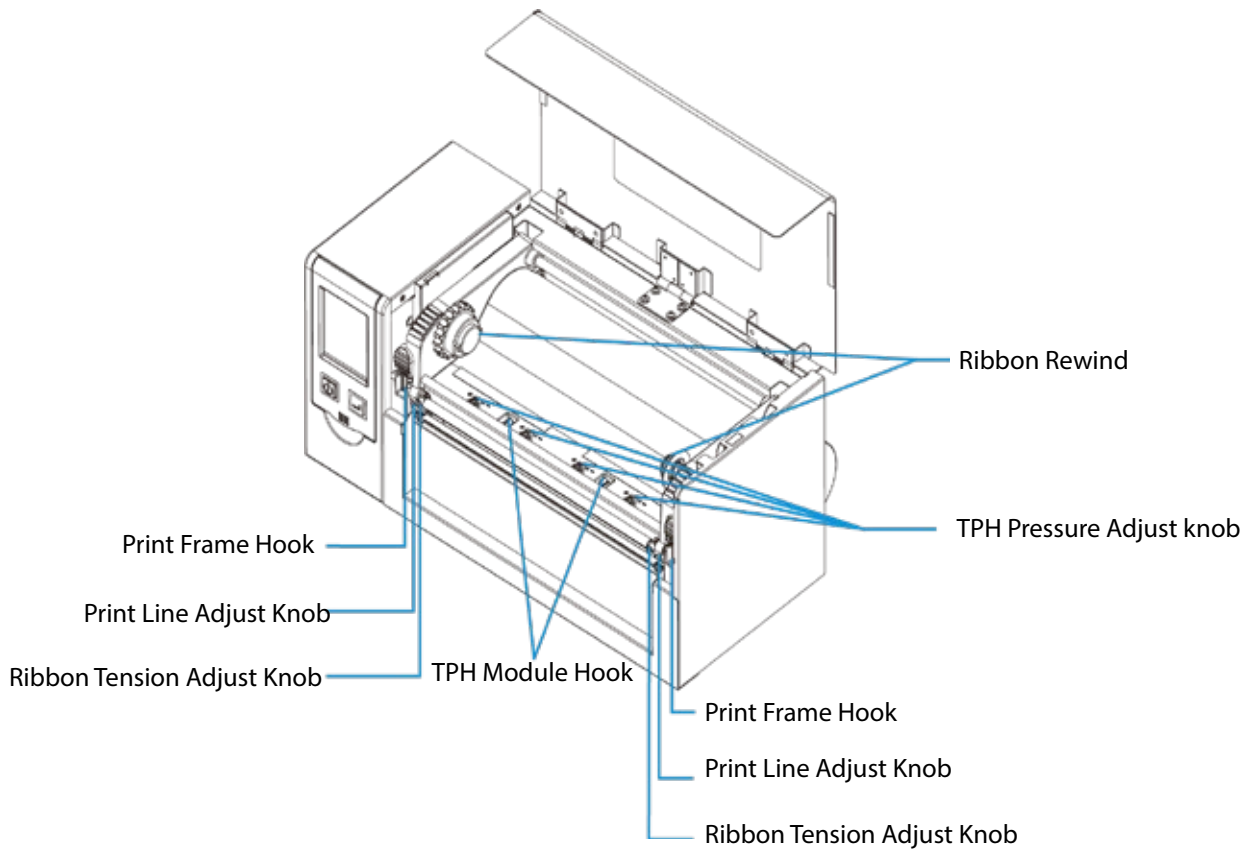

Section 2: Printer Installation

2.1 Media Installation

Lift up the top cover

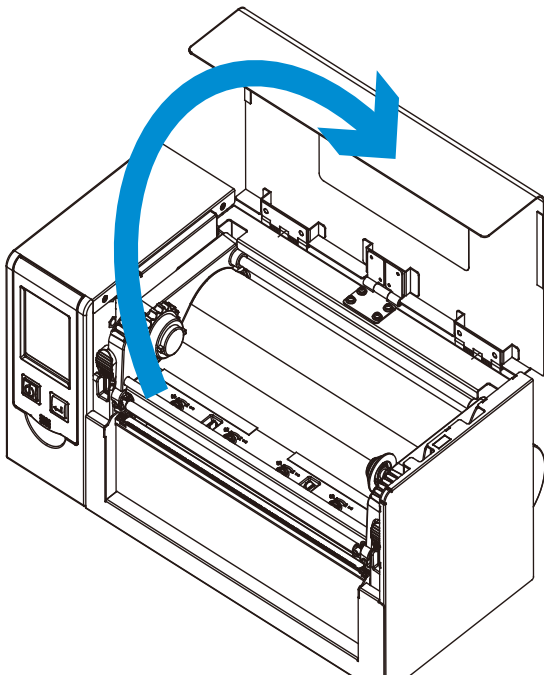

2.2 Printing Mechanism Opening

Push the Print frame hook on the side to head up the print frame.

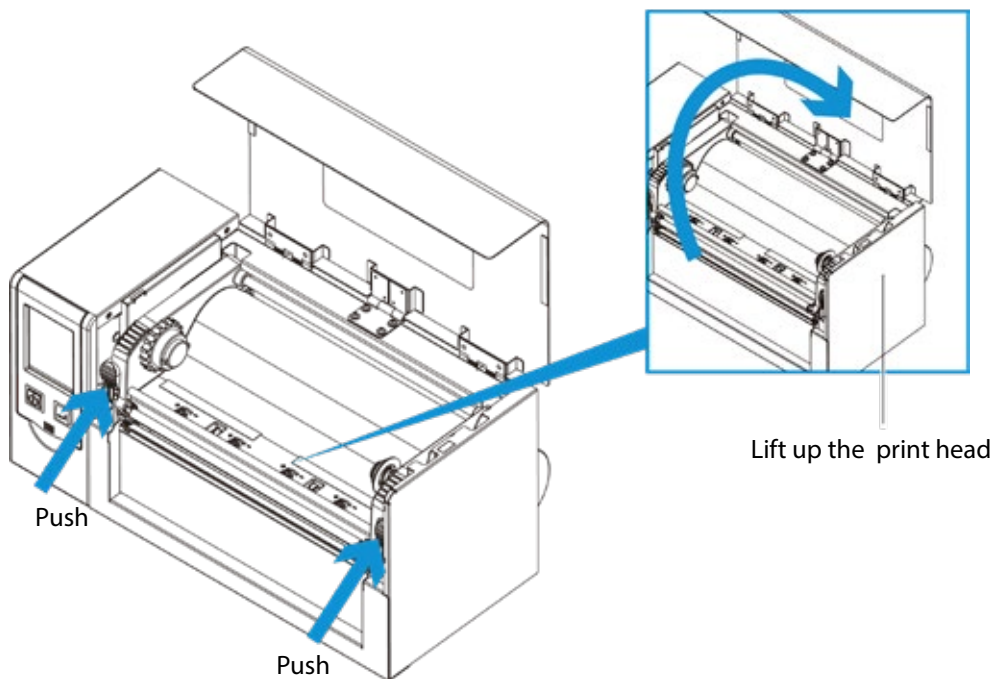

2.3 Ribbon Installation

Smaller than 8 inch or multiple ribbons

Please make sure to place the ribbon and the empty core exact on the same position where the foil should be applied to your label. When using more than one ribbon, make sure to always use equal rolls so that they can be unrolled evenly.

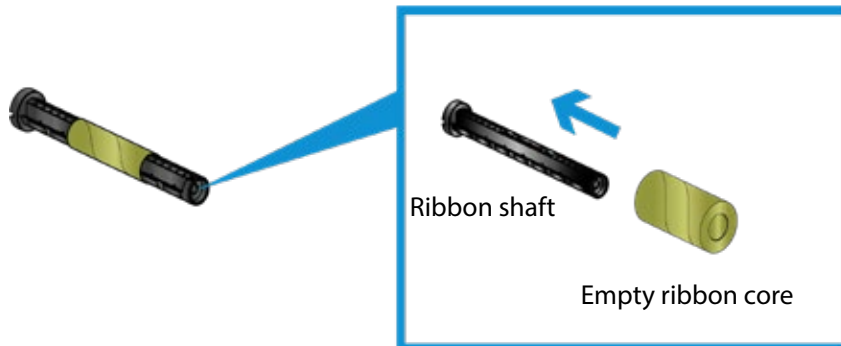
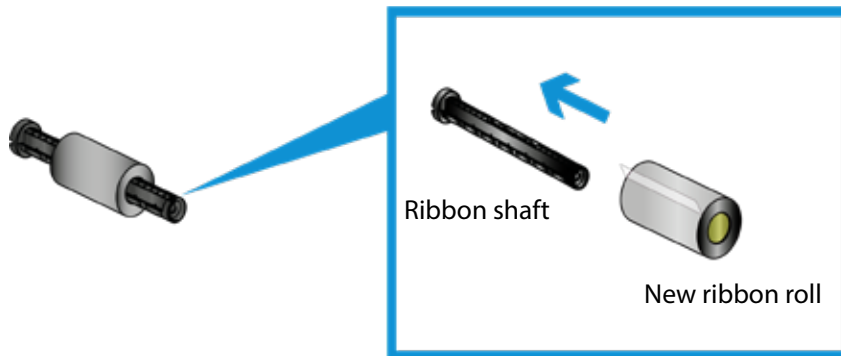

Stick the ribbon on the empty ribbon core and roll it up.

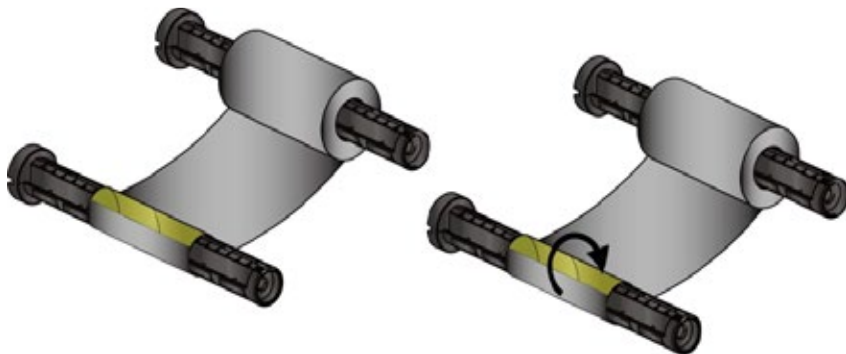

8 inch ribbon

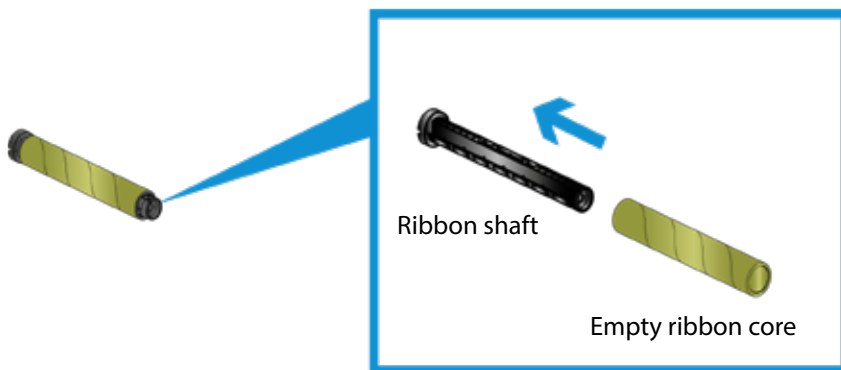
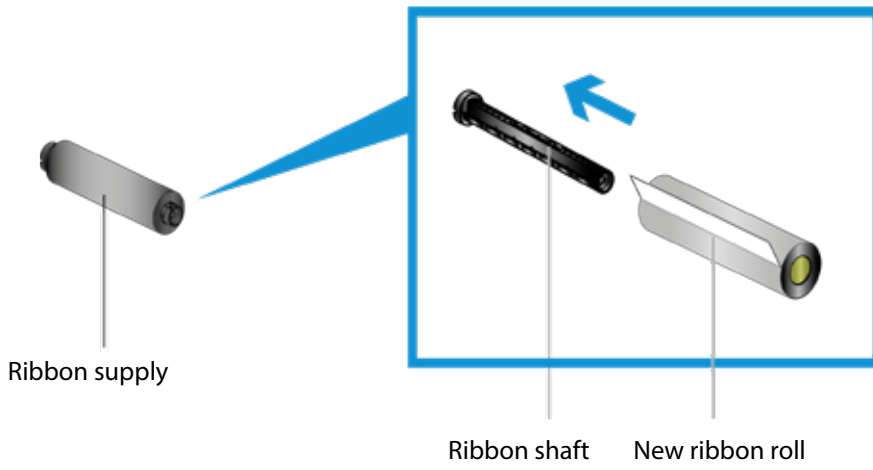

Stick the ribbon on the empty ribbon core and roll it up.

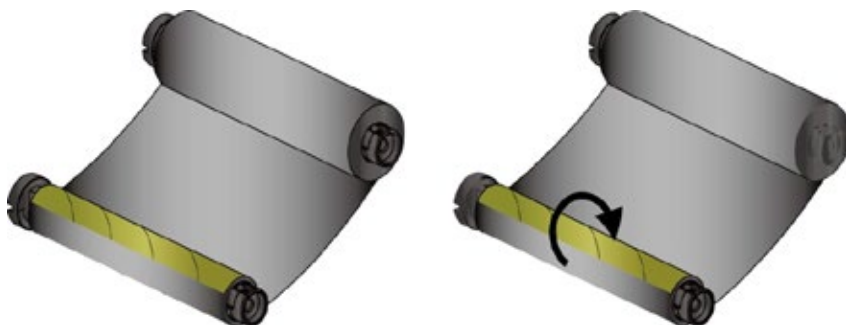

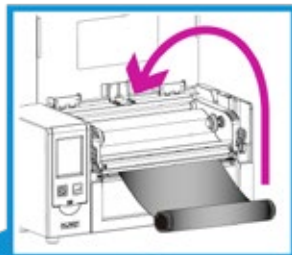
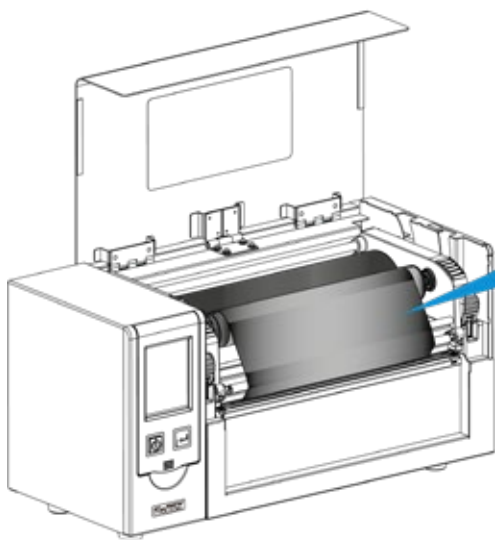
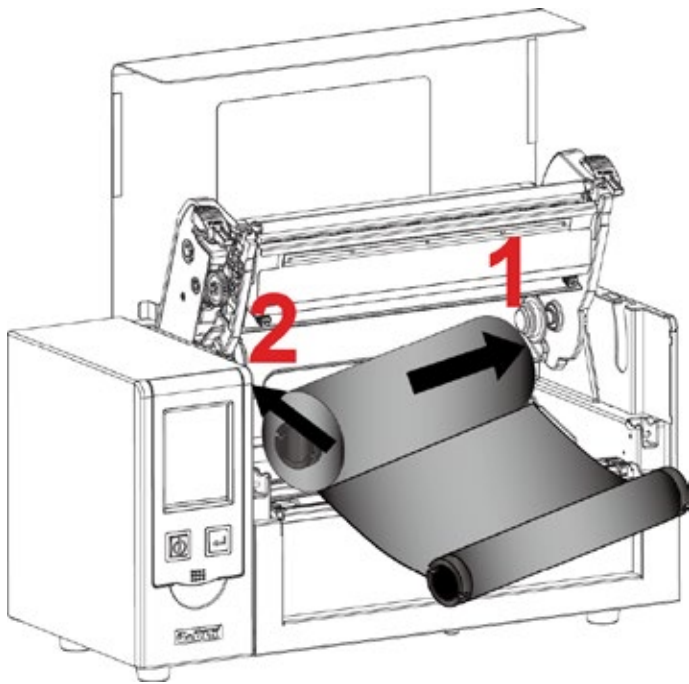

Put the ribbon rewind assy into position

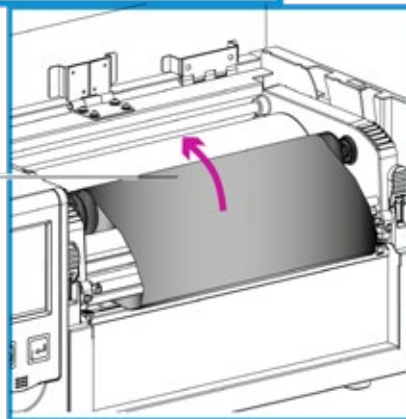

Rolling to flat surface.

2.4 Media Specifications

A wide variety of label stock can be used in the printer. Refer to the following specifications and settings before ordering custom stock from DTM.

Important! Test all custom made label stock with the intended printer before ordering large quantities!

The media stock must have one of the following sensormarks:

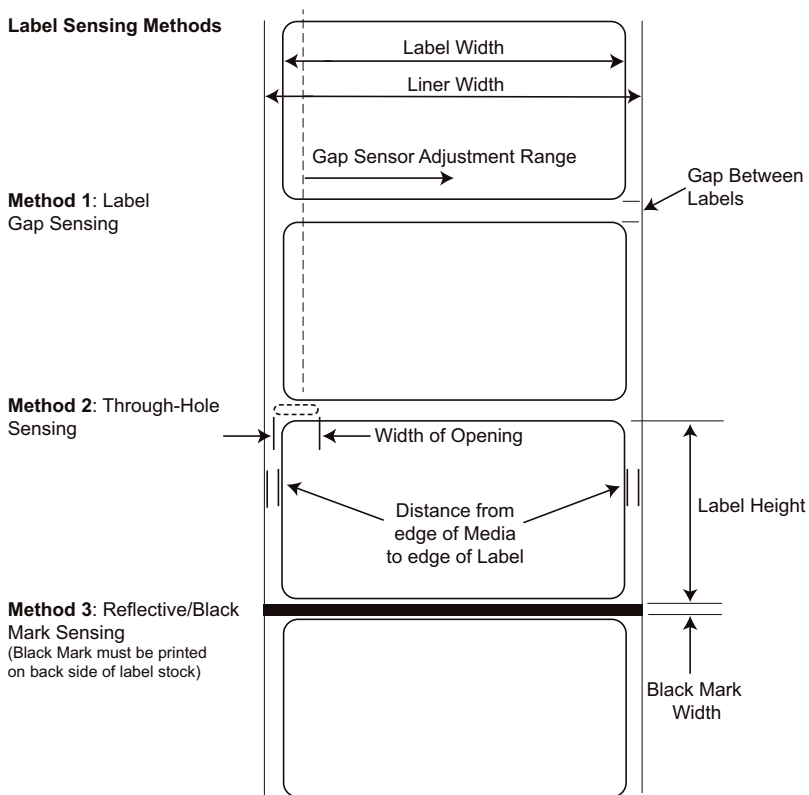

GAP

Black mark

Use black mark for label material where a black pre-printed line on the back of the label stock indicates the break between labels. Black marks are required on clear label stock rolls, or label where the label waste matrix (waste) is left on the liner. Black marks can also be used for irregular shaped labels, circles larger than 4 inches or on any stock where the print starting position can not be sensed using the label itself.

Should be opaque to infrared light. The mark should be between the labels. The end of the mark should correspond with the beginning of the label.

Continuous

If you have continuous stock with no die-cut, reflective mark or holes, set the sensor type to Continuous. This will turn off the stock sensor. In this mode there is no way to set the print starting position. The printer will simply start printing the first label and print each subsequent label immediately after that previous one. To produce a gap between prints simply add the desired amount of white space to the end of the label being printed.

Important! For pre-printed continuous substrate black mark is mandatory.

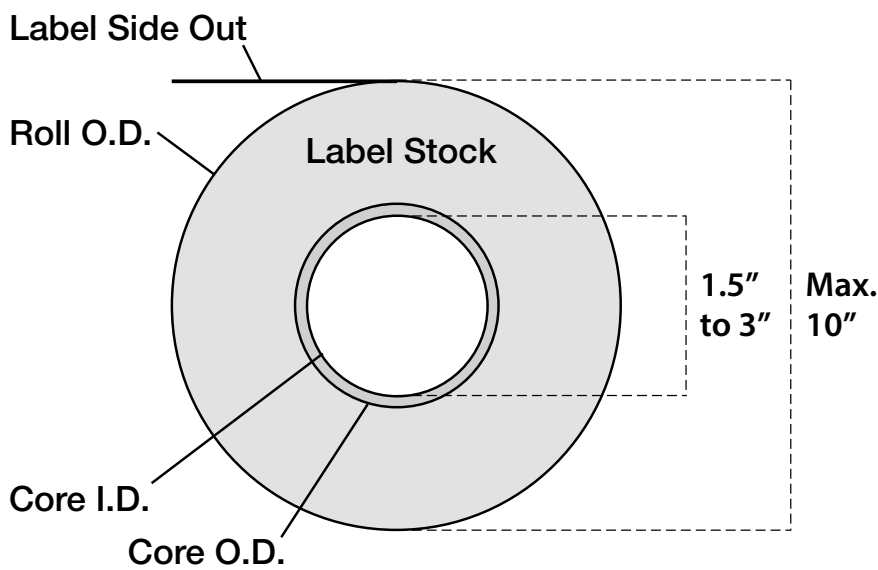

Note on Label Orientation

If you are using an applicator to apply your labels, be sure to order label stock with the correct orientation for your applicator. For example most applicators will apply the side of the label first, so you will want to print the labels sideways.

2.4.1 Label Installation

Label Holder Stand - Label Installation

Step 1. Following the arrow mark and No. to put the label roll holder into position.

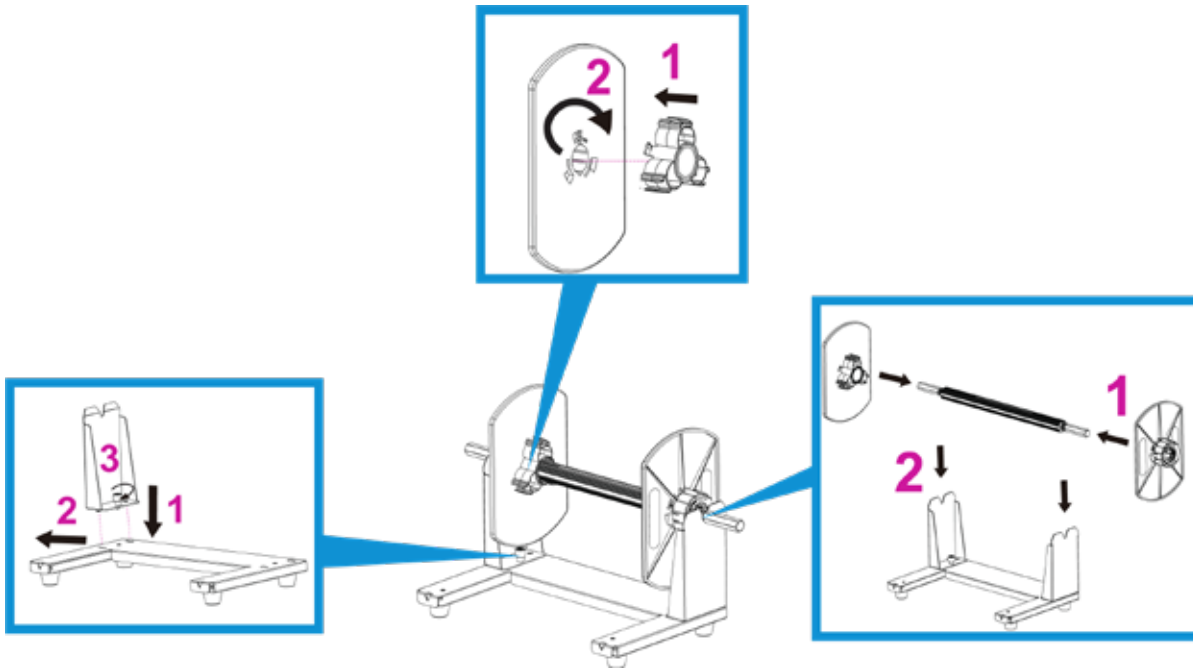

Place the stand behind the printer and hook it.

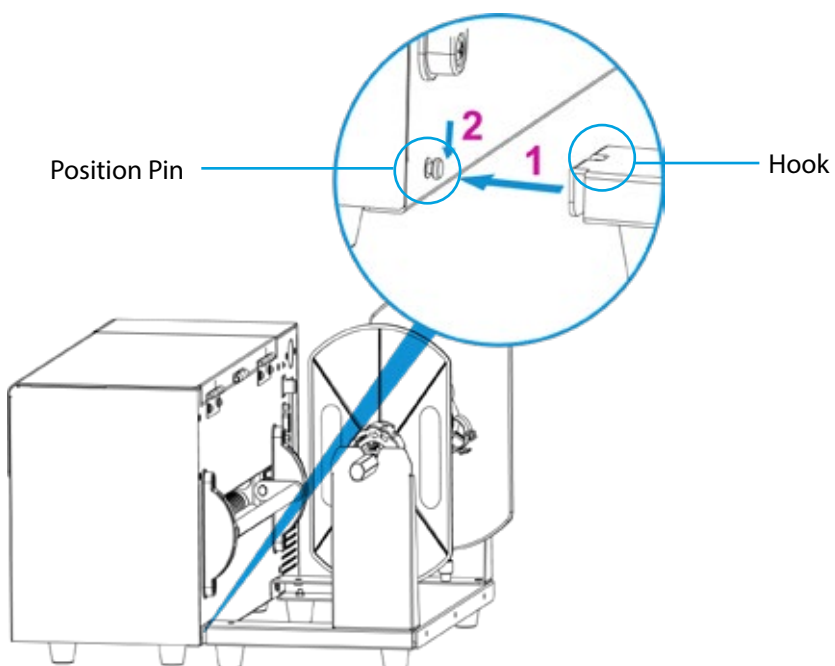

Put the label roll into media spindle and then install the label roll stopper on the both side to make the media roller in position.

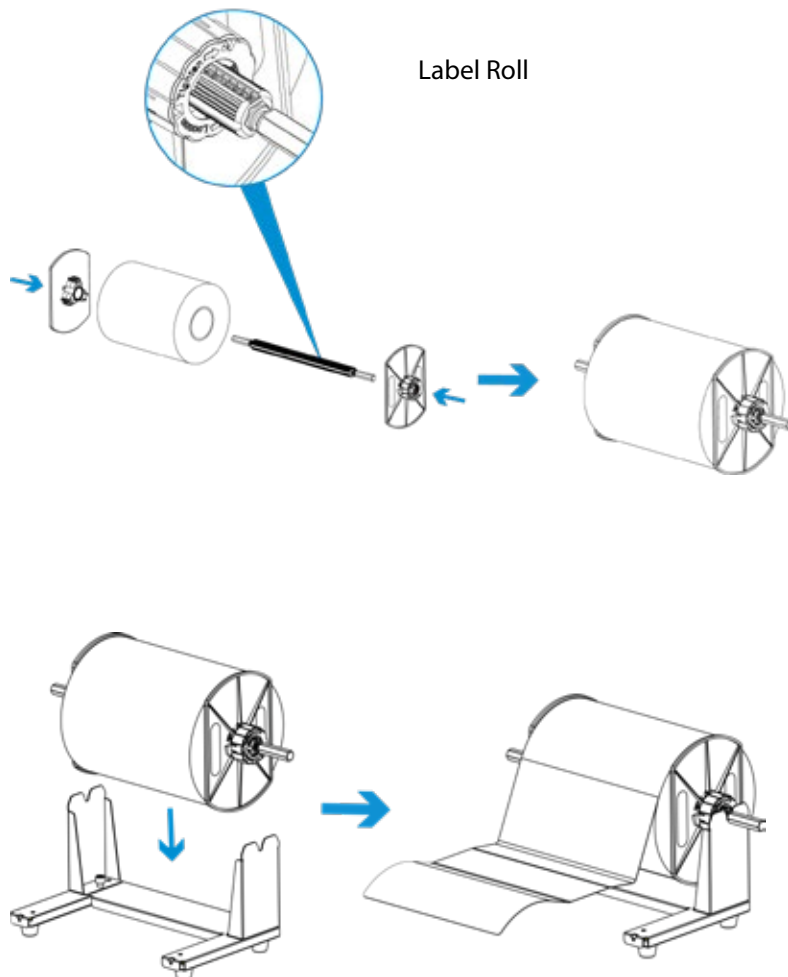

Put the label pass through the label guide and then adjust the suitable label width according to.

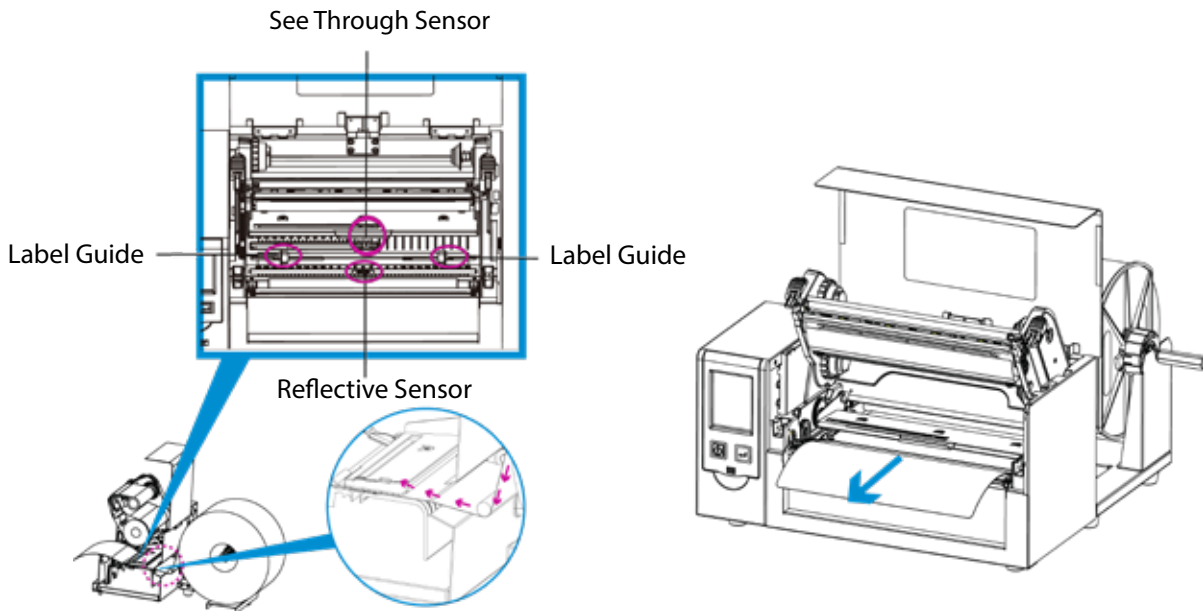

Inside Label Roll Installation

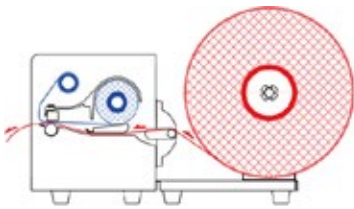

Outside Label Roll Installation

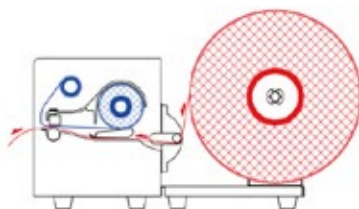

Fanfold paper Installation

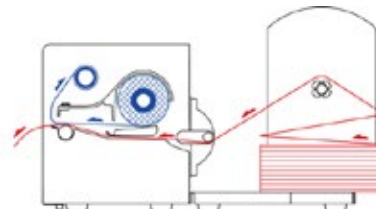

2.5 Connection with PC

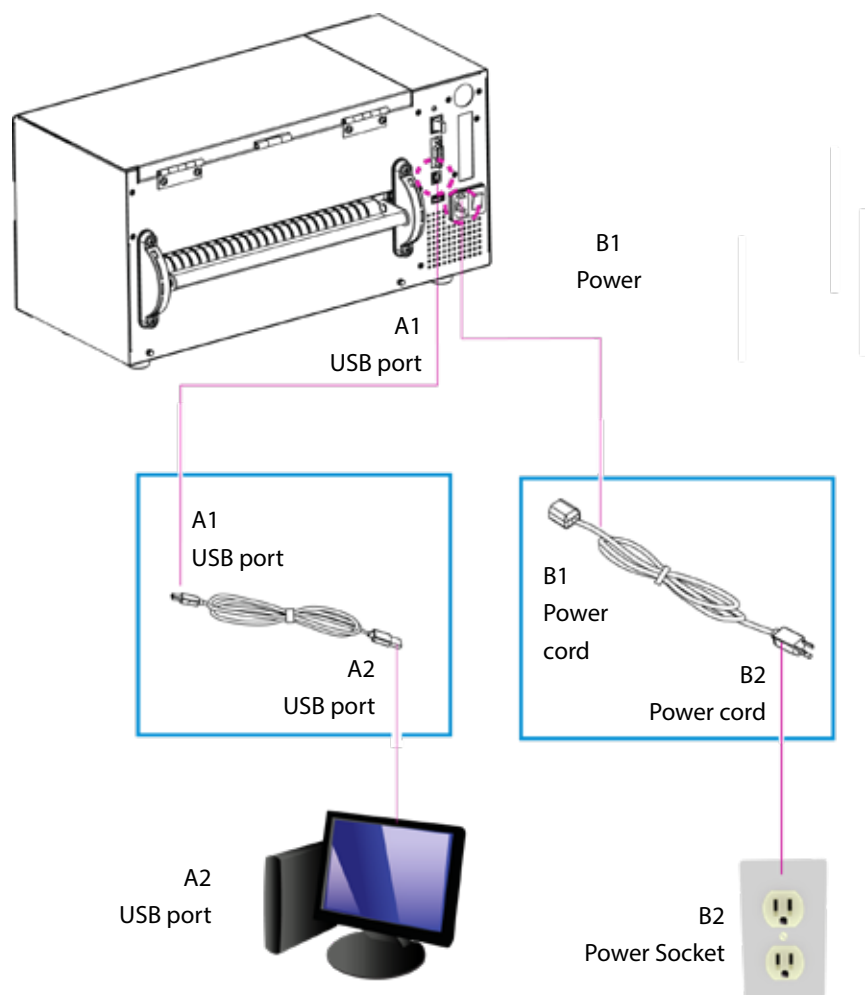

2.6 Installing The Driver

1. Download the driver at dtm-print.eu/download
2. Select the icon for the driver file and double-click to start the installation.
3. Follow the instructions on the screen. The Driver Wizard guides you through the installation procedure.
4. Select "Install printer drivers".
5. Choose "DTM FX810e"

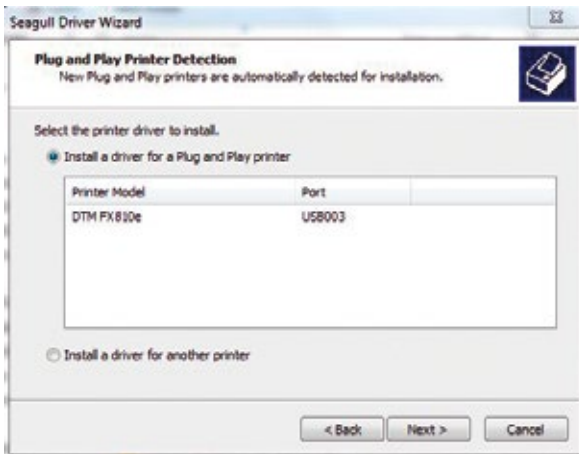

6. Enter a printer name and assign the appropriate rights.

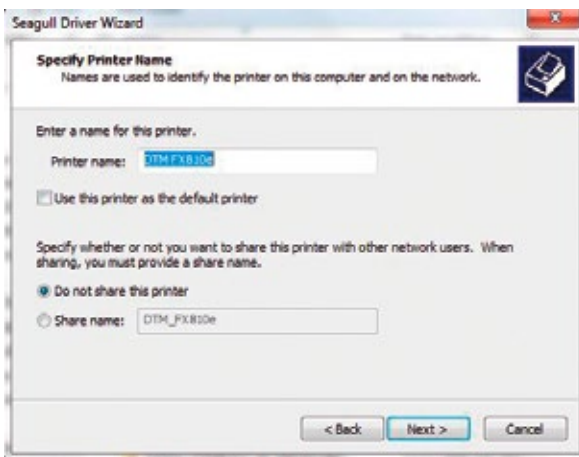

7. Once the installation is complete, a summary of the printer settings is displayed.
8. Check whether the printer settings are correct and click "Finish" to start copying the driver files.



9. Wait until copying is complete, then finish the installation.
10. Once the driver installation is complete, the new printer should appear in the "Devices and Printer" folder.



Section 3: Printer Operation

3.1 Printer Operation Interface

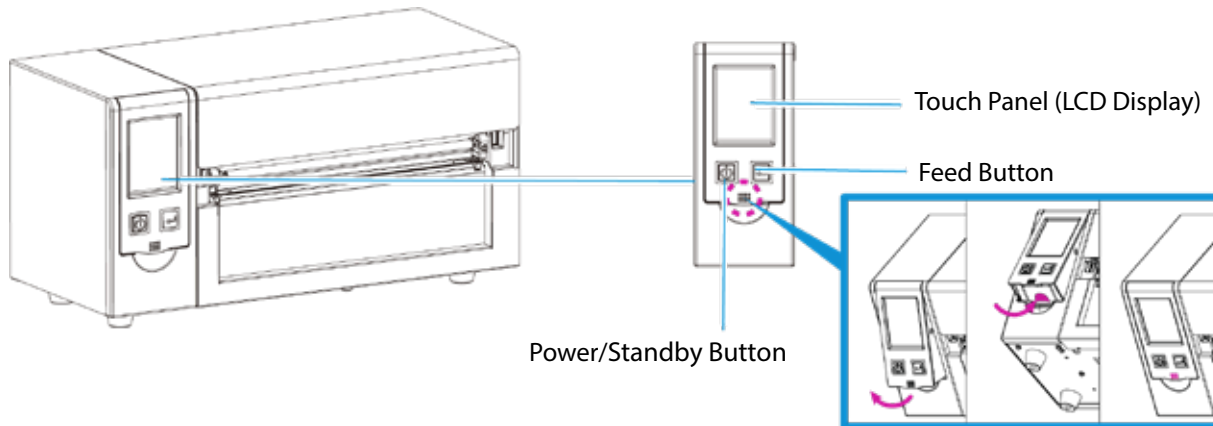

Standby button

Make sure the power switch is on. pressing the "Standby button", wakes up the printer and the display will show "Ready". Press and hold the "standby button" for 3 seconds will set the printer back in Standby Mode.

Feed button

When pressing the FEED button, the printer moves the label to the defined stop position. If you are using continuous labels, pressing the FEED button will move label stock until you release the button again. If you are using individual labels, pressing the FEED button will move only one label. If the label does not stop at the correct position, please run the auto calibration (See Section 3.4 Label size calibration and Self Test Page) for the label size calibration function on the label stock.

Pause _ Feed button

If you want to pause the printing, press the feed button. The printer will be on pause status, the LCD will show "Pause" till you press the feed button again to release the Pause Mode.

Cancel Printing_ Feed key

Press and hold feed key for 3 seconds during printing will clear the print job and the Printer will be set to standby mode.

3.2 LCD Operation Introduction

Getting Started

Press the POWER button to turn on the printer, and the START UP SCREEN appears.

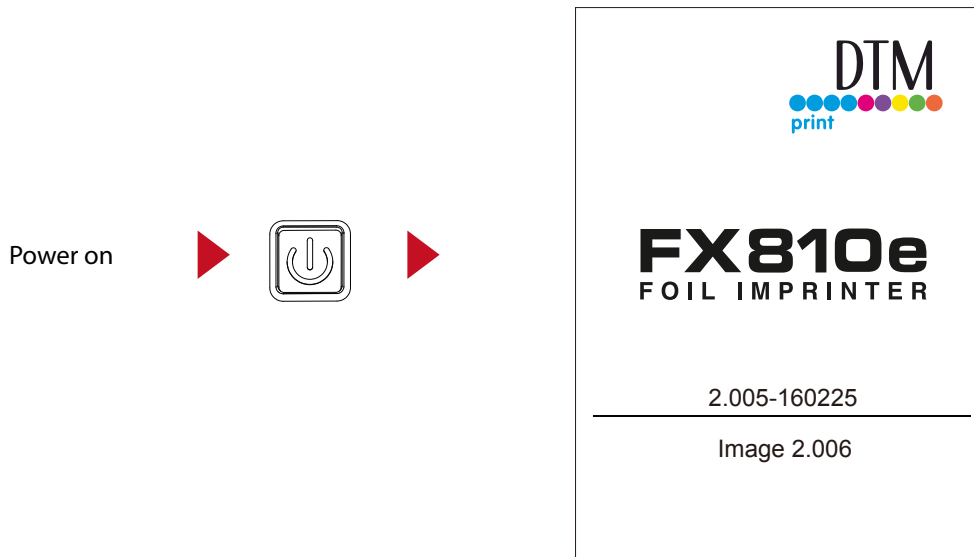

If the printer is on "ready to print" status, the LCD screen should display the message "Ready" on the screen.

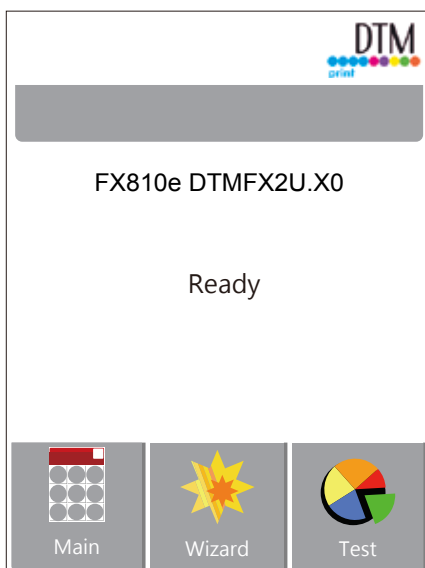

On the Ready Screen there are three menus to select. Pressing one of them will open a new menu with further options.

Tap "Main" to enter the sub-screen which offers more functions.

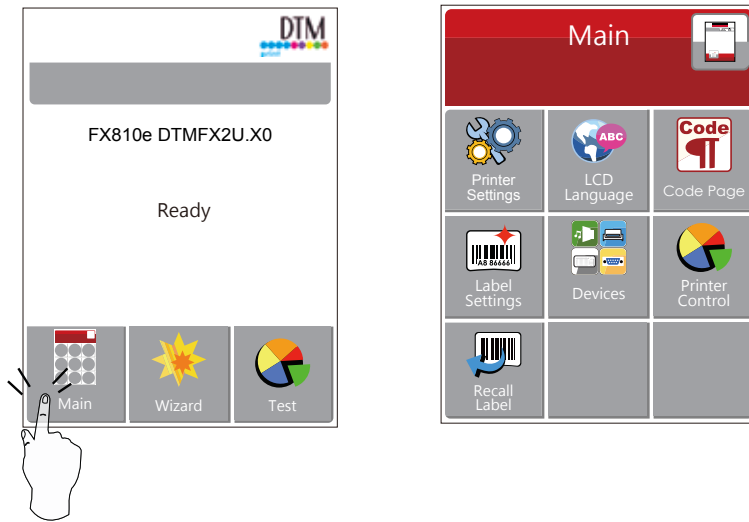

Tap "Wizard" to set up "Darkness" or "Speed"

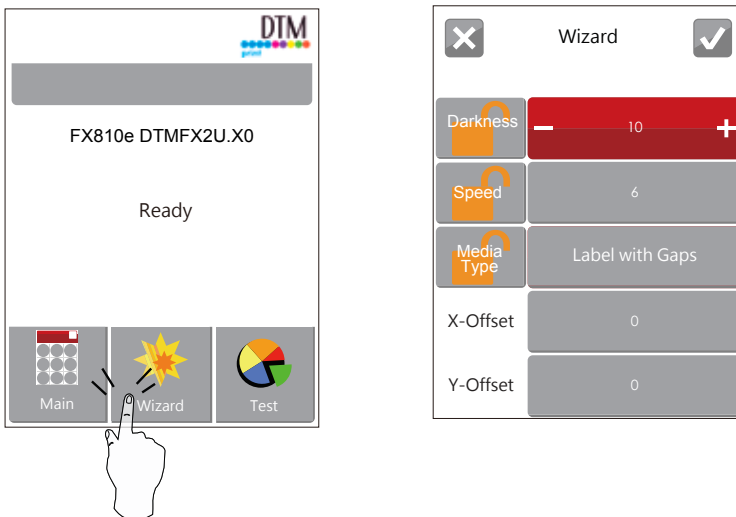

Tap "Test" for Self-Test page and to execute the Calibration.

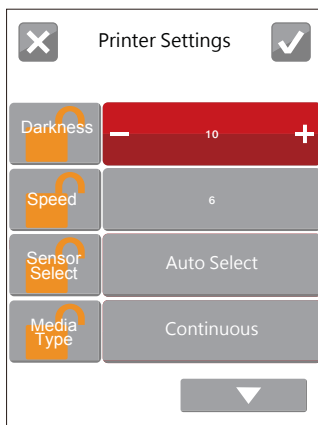
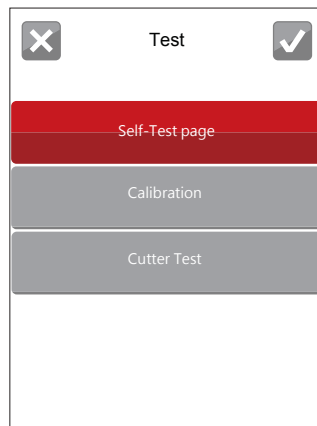

Press  to save and to go back to Main Page.

Press  to go back to Main Page without saving the changes.

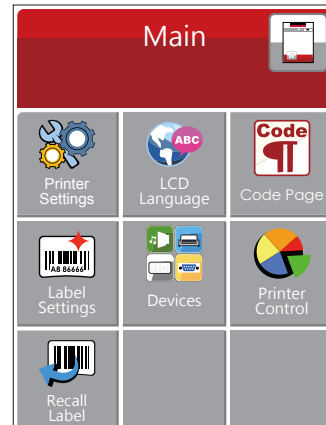

Unlock



Lock

If printer functions locked, the printer can not modify settings from any device.

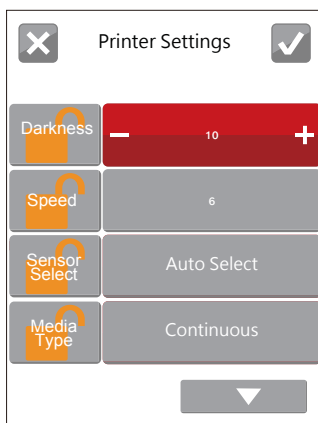

Keyboard Mode

When plug-in an USB keyboard to the printer, LCD touch panel will display “Enter Standalone”, press the “Y” key on keyboard to enter to the dialog for “Keyboard Mode” operation.

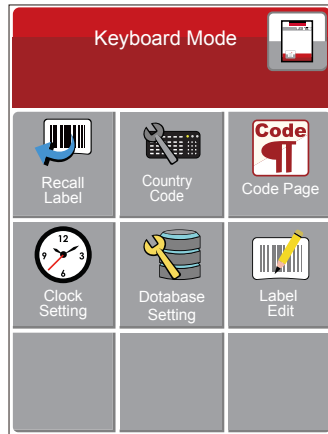
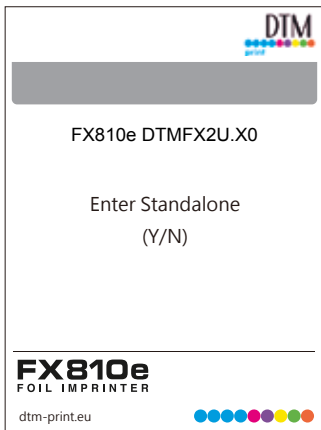

Tap on Main and then on Recall Label to recall the label.

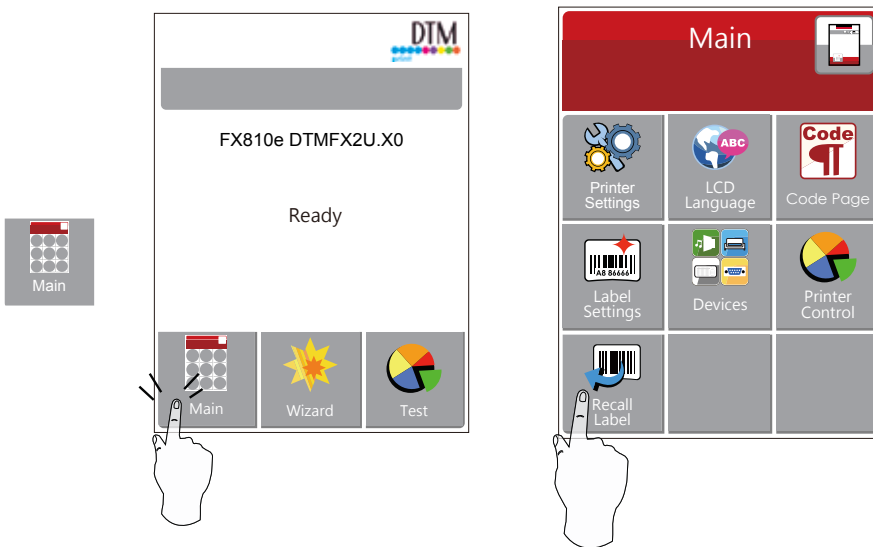

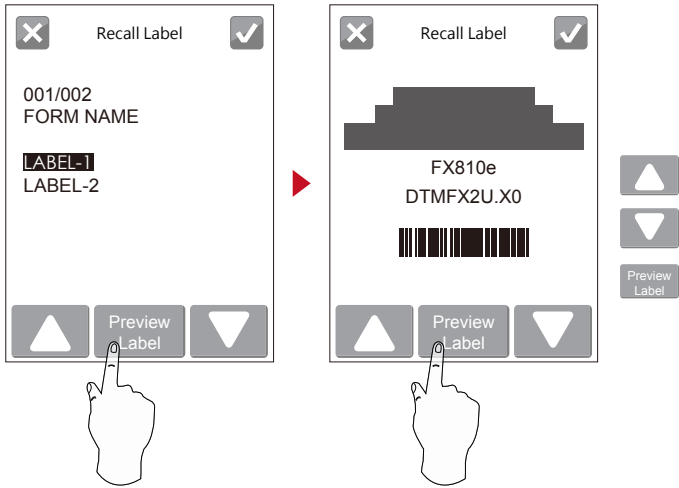

The touch panel shows all labels. The Data processing time will be extend as long as the labels increase.

Tap to choose the label. Tap Preview Label to see a preview before printing the label.

Tap on to set the settings, tap on again to print your label.

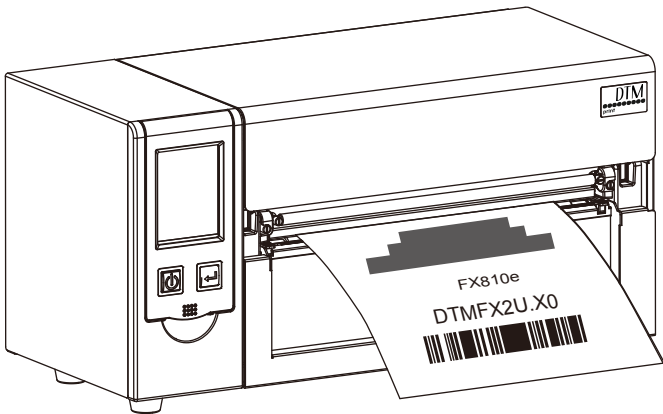

Label has been printed.

3.3 LAN Setting Operation Instruction



Setting printing speed and darkness. Also includes a Printing Wizard for your ease of printing.



10 languages for printer setting



It consist of a label of values that describes the character set for a particular language



Setting items for printing label, ex.Prtation, Printing position offset



Providing Buzzer, Option Setting, Smart Backfeed, Serial Port Setting, LAN Setting, LCD Setting, Clock Setting, WiFi setting, and Bluetooth Setting



If-Diagnose functions for printer, ex. Callibration, Sel-Test page and Clear Memory



Recall Label and preview label

Device Page

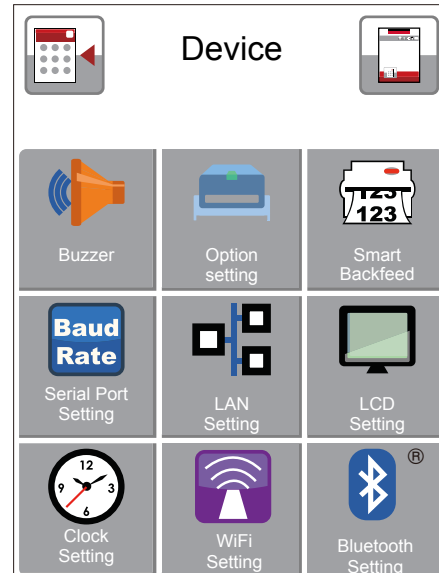

Setting off or on for buzzer



Setting items for options, ex. Cutter, Label Dispenser, Applicator



Setting off or on for Preview Label



Setting items for Serial Port, ex. Baud Rate, Data Bits, Stop Bits.



Setting item for LAN, ex. DHCP, IP Address, Subnet Mask, Gateway









Setting items for LCD, ex. off or on for Password function, Correction



Setting items for Clock, ex. Year, Month, Day, Hour, Minute and off or on for Visible function

Setting items in LCD Setting Mode

	Printer Setting	Darkness	0-19
		Speed	2-3
		Sensor Select	Auto Select, See-Through, Reflective
		Media Type	Label with Gaps, Label with Marks, Continuous
		Printing Mode	Direct Thermal, Thermal Transfer
		Tear-off Position	0-4
		Top of Form	Off, Full, Door Open Only
		Program Language	Auto, EZPL, GEPL, GZPL
	LCD Language	English, Deutsch, Francais, Espanol, Italiano, 簡體中文, 繁體中文, Türkice, 日本語, Pycnnc	
	Code Page	850, 852, 437, 860, 863, 865, 857, 861, 862, 855, 866, 737, 851, 869, Windows 1252, Windows 1250, Windows 1251, Windows 1253, Windows 1254, Windows 1255, Windows 1257	
	Label Setting	ROTATION 0°, 90°, 180°, 270° X-Offset -100 : + 100 Y-Offset -100 : + 100 Start-Offset -100 : + 100	
		Buzzer	OFF, ON
		Option Setting	None, Cutter, Label Dispenser, Applicator
		Smart Backfeed	OFF, ON
	Devices	Serial Port Setting Baud Rate: 4800, 9600, 19200, 38400, 57600, 11520 Parity: None, Odd, Even Data Bits: 7, 8 Stop Bits: 1, 2	
		LAN Setting	DHCP: OFF, ON IP Address 0.0.0.0 Subnet Mask: 255.255.255.0 Gateway: 192.168.0.254
		LCD Setting	Pasword: OFF, ON, Correction
		Clock Setting	Year, Month, Day, Hour, Display: On, Off
	Printer Control	Test: Configuration, Directory, TPH Testing, Dump Mode Sample Pattern: Self-Test page/Balance Select Memory: Internal/External, Label Format, Graphic Clear Memory: Bitmap Fonts, True Type Fonts, Asian Fonts, All Calibration: Reset to Default	
	Wizard	Darkness: 0 - 19 Speed: 2 - 3 Media Type: Label with gaps, Label with marks, Continuous X-Offset: -100 : +100 Y-Offset: -100 : +100	

LCD Operation

When Barcode Printer is Ready, the LCD will display "Ready"

And then the printer is ready to print

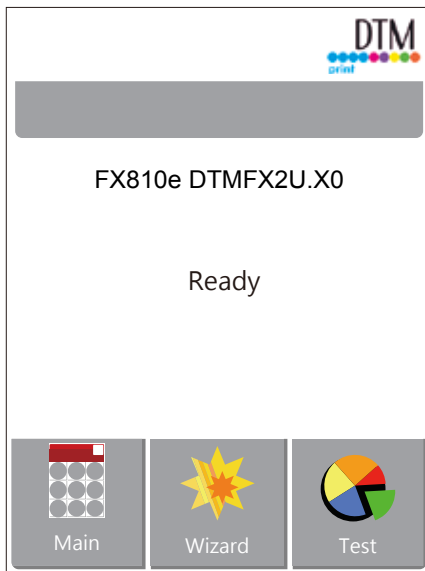

If there is any error occur, there will be Error Message shows on the LCD. You could do the trouble shooting according to or contact with the agent.

WARNING ICON

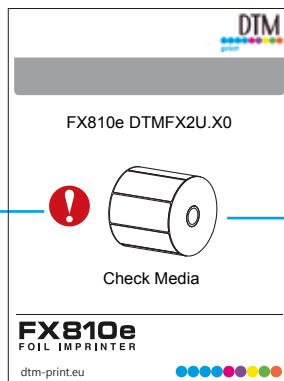

ERROR ICON

ERROR DESCRIPTION

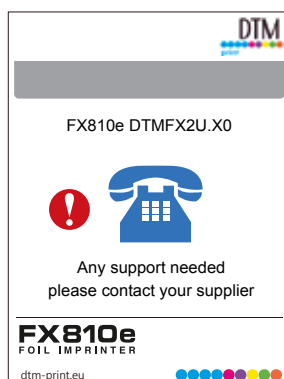

3.4 Label size calibration and Self Test Page

The printer can automatically detect and store label height. That means the host computer does not need to transmit the label height to the printer. And the self self-test function lets you check whether the printer is functioning normally. Here is how you run the label size calibration and self test test.

- Step 1 Check that the label stock is loaded correctly.
- Step 2 Switch off the printer.
- Step 3 Switch the printer on again, keeping the FEED button pressed. When the READY LED starts to flash red and the STATUS LED lights up orange, release the FEED button. The printer will now measure the label stock and store the label height
- Step 4 Once the printer has successfully measured the label stock, it will print a self self-test label.

The contents of a self self-test printout are listed below.
 (The data below is for reference only, actual result may vary according to each situation.)

Printer Model and Firmwave info	DTM FX810E:Y2.XXX
USB Port Setting	USB S/N:12345678
Serial Port Setting	Serial port:96,N,8,1
MAC Address Info	MAC Addr:xx-xx-xx-xx-xx-xx
DHCP Enable or Unable	DHCP Enable
Ethernet IP Setting	IP xxx.xxx.xxx.xxx
Gateway Setting	Gateway xxx.xxx.xxx.xxx
Sub -Mask Setting	Sub-Mask xxx.xxx.xxx.xxx
Card Status	Card Status:HW Unable to detect any card
Network Status	Network: Cable Not Plug
	#####
DRAM info	1 DRAM installed
Imabe Buffer Size	Image buffer size:1500 KB
Forms storage info	0000 FORM(S) IN MEMORY
Graphics storage info	0000 GRAPHIC(S) IN MEMORY
Fonts storage info	000 FONT(S) IN MEMORY
Asian fonts storage info	000 ASIAN FONT(S) IN MEMORY
Database Storage info	000 DATABASE(S) IN MEMORY
TTF storage info	000 TTF(S) IN MEMORY
Memory Size	4073 KB FREE MEMORY
Speed, Darkness , Ref. Point, print direction	^S4 ^H8 ^R000 ~R200
Media width,length, gap setting info	^W102 ^Q100,3 ^E18
Options setting info	Option:^D0 ^O0 ^AD
Reflective Detecting Info	Reflective AD:1.96 2.84 2.49[0.88_23]
Code Page Setting	Code Page:850

Auto-Calibration

Press and hold the calibration button for 2 seconds when media has been replaced or media error occurred to adjust the media size.

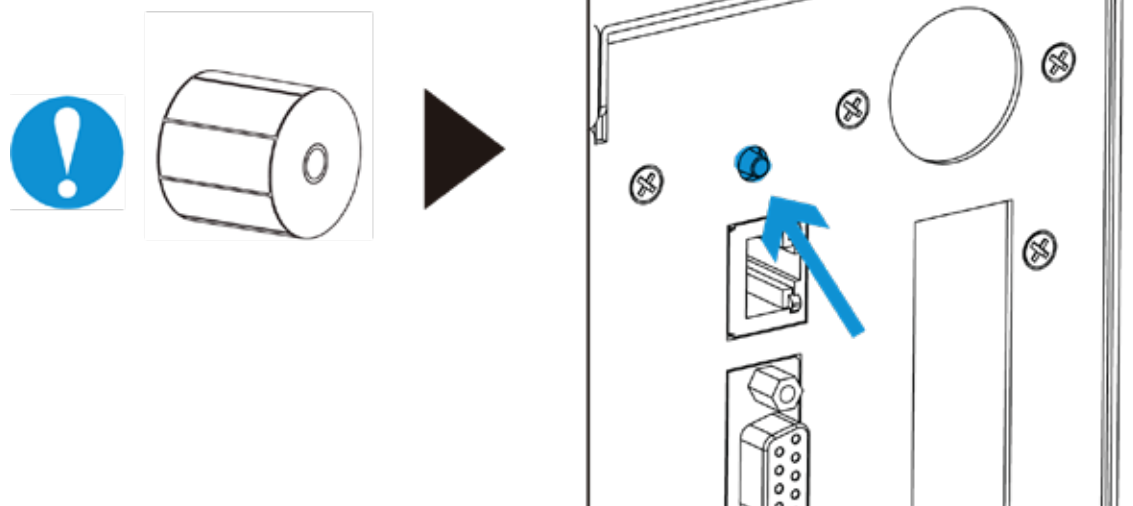
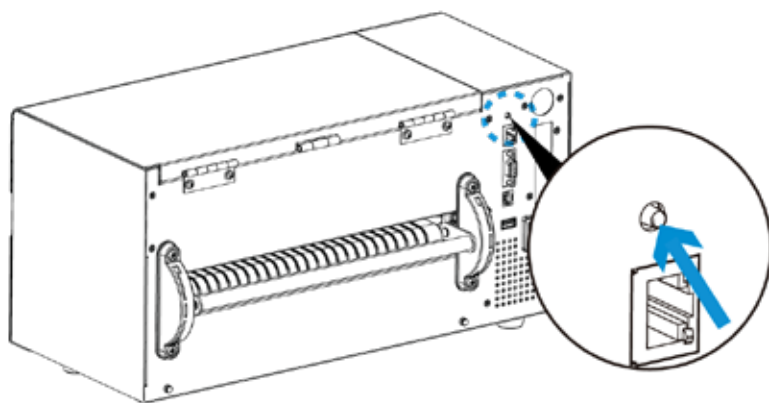

3.5 Error Message

If there is any error occurred during the printing, LCD will display the Error message and also buzzer as warning.

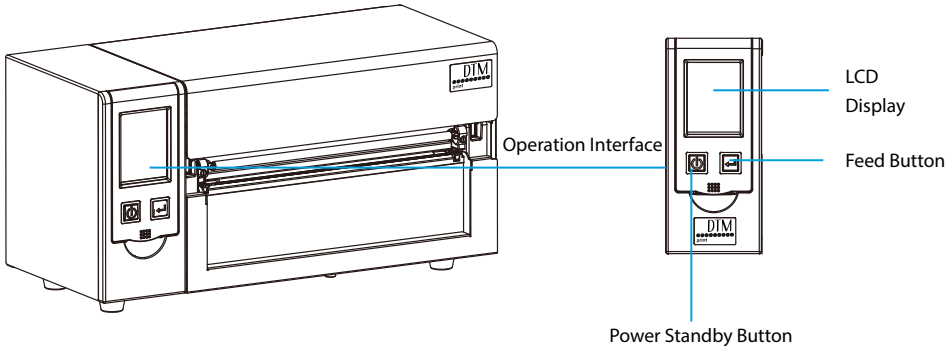

	Type	Beeps	Description	Solution
<p>FX810e DTMF2U.X0 Door Open Only</p> <p>FX810e FOIL IMPRINTER</p> <p>dtm-print.eu</p>	Printhead Open	2x4 beeps	Printhead is not closed correctly.	Check the printhead.
<p>FX810e DTMF2U.X0 TPH Over Heat</p> <p>FX810e FOIL IMPRINTER</p> <p>dtm-print.eu</p>	TPH Over Heat	None	High temperature at the print head	Once the print head has cooled down, the printer switches to standby mode.
<p>FX810e DTMF2U.X0 Check Ribbon</p> <p>FX810e FOIL IMPRINTER</p> <p>dtm-print.eu</p>	Media Error	2x3 beeps	No ribbon is installed and the printer displays an error.	Make sure that the printer is set to direct thermal printing mode.
The ribbon is finished or the label supply hub is not moving			Replace the ribbon roll.	

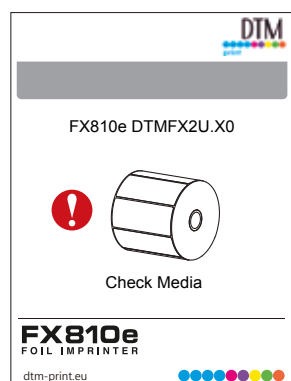

Type	Beeps	Description	Solution
Media Error	2x2 beeps	No paper is detected.	Make sure that the label sensor is positioned correctly. If the sensor still does not detect the paper run the auto detection function again.
		Paper is finished	Replace the the label roll.
		Printer feed problem.	Possible reasons: the print medium has become trapped around the rubber roll;the sensor cannot detect a gap or black mark between the labels; there is no paper.Please reset the sensor.
File Error	2x2 beeps	The memory is full. The printer prints the message "File System full".	Delete unnecessary data or install additional memory.
		Unable to find file. The printer prints the message "File not found"	Use the "~X4" command to print all files.Then check whether the files esixt and whether the names are correct.
		A file of the same name already exists. The printer prints the message "Duplicated Name"	Change the name of the file and try storing it again.

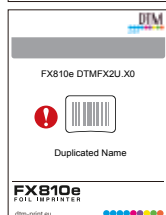
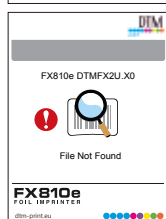
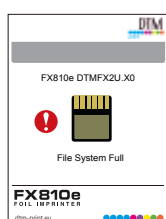

3.6 Connected with USB Devices

USB Host port supports USB memory stick, USB keyboard or scanner.

USB memory stick: It extends the user memory space for Graphic, Font, Label Foemat, DBF and Command file downloading. The printer's Firmware also can be updating if copy new version of Firmware into USB memory stick.

Connecting an USB keyboard to printer for "Keyboard Mode" mode operation.

Plug-in an USB scanner to operate the printer in "Keyboard Mode".

Usage of Extended Memory

USB memory stick: It supports hot-plugging function; printer will create a Folder "\LABELDIR" and switch " User Flash" to "Extended Memory" automatically while user plugs an USB memory stick into a printer.

Connect USB with the printer; To connect PC and printer through USB.

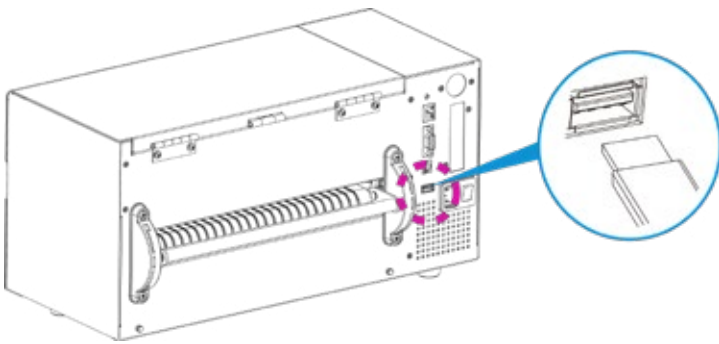

Usage of Firmware Update

- ▶ Remove USB memory stick from printer and plug-in it to a PC's USB port.
- ▶ Copy a new version of firmware "xxx.bin" to the Folder "\LABELDIR\FW"
- ▶ Remove USB from PC and plug-in back to the printer. The printer will update the Firmware automatically
- ▶ The "\LABELDIR\FW" directory allows only one file exist, if there are multiple files, the files will be confused.
- ▶ Don't remove the USB memory stick out while it's under updating with "Flash Writing ..." message that displays on LCD panel

USB keyboard

- ▶ When plug-in an USB keyboard to the printer, LCD touch panel will display "Enter Standalone", press the "Y" key on keyboard to entering "keyboard Mode" operation. Under this model can perform "Recall Label", set "Country Code", "Code Page", "Clock Setting", "Database Setting" and "Label Edit".
- ▶ Connect a USB keyboard to the printer, if not into the keyboard mode, press the "N" key to leave.
- ▶ Into Standalone mode of operation, to leave the Standalone operation, press "ESC" key to exit.
- ▶ After leaving the keyboard mode, for re-entry, press the key "F1" key or reboot, you can follow the steps in the first step choose whether or not (Y/N) into the keyboard mode.

Scanner

- ▶ When plug-in an USB scanner to the printer, LCD touch panel will display "Enter Standalone", tap the "Feed" key to entering "Keyboard Mode" operation.

Section 4: Optional Cutter Installation

Turn the FX810e off and open the Top Cover

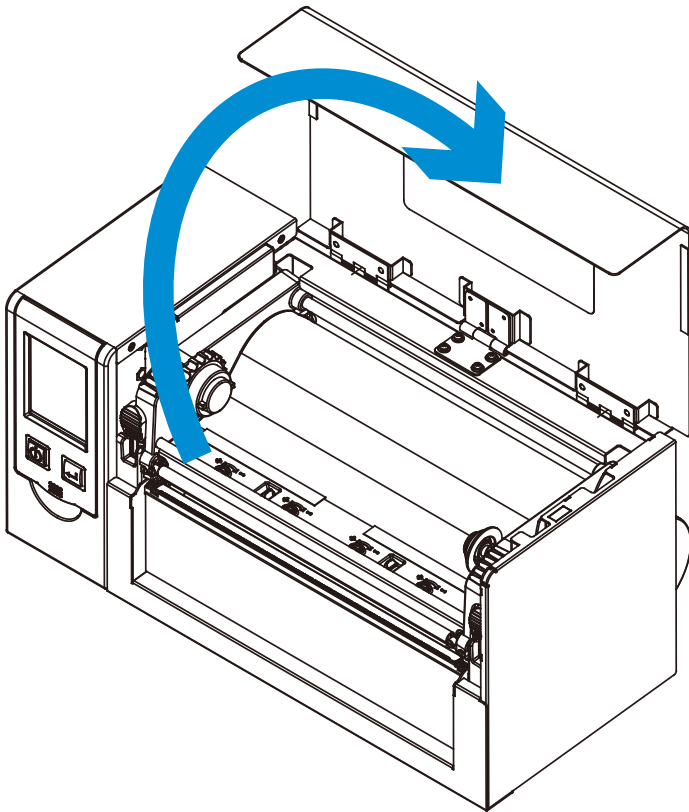

Cutter Parts

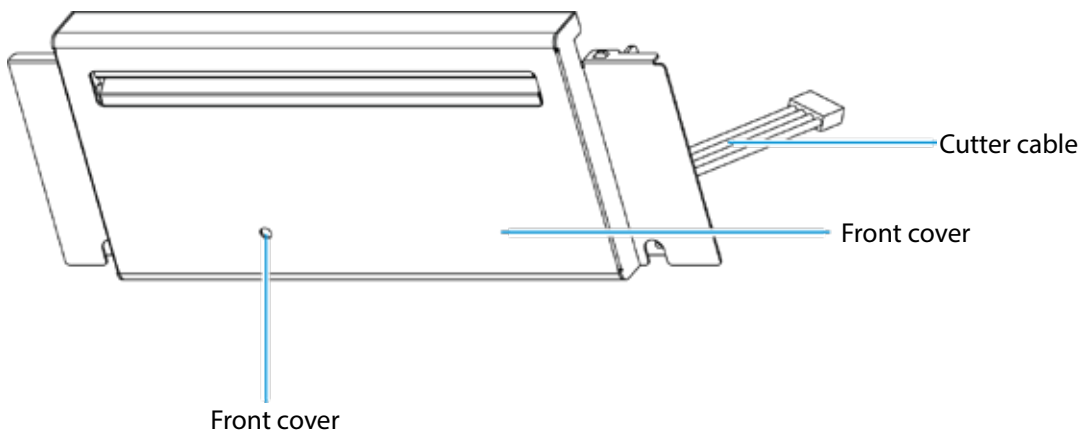

Disassemble the bottom case screws (marked in red circle).

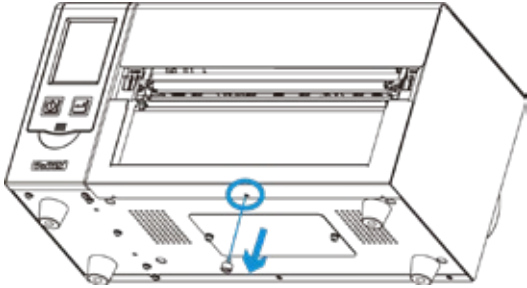

Open the printhead and remove the front panel.

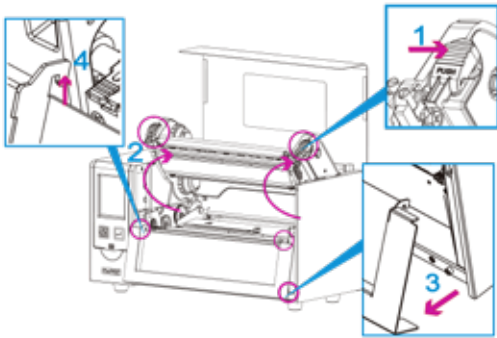

Connect the cutter cable into the printer and hook the cutter panel to the printer.

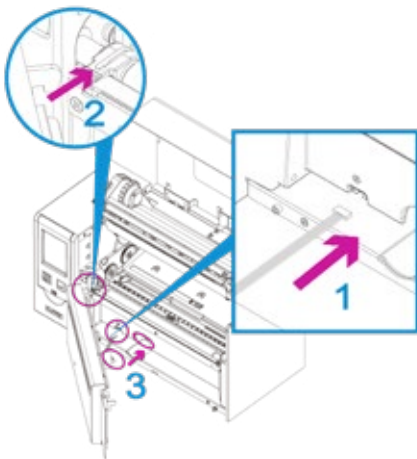

Screw the panel as shown.

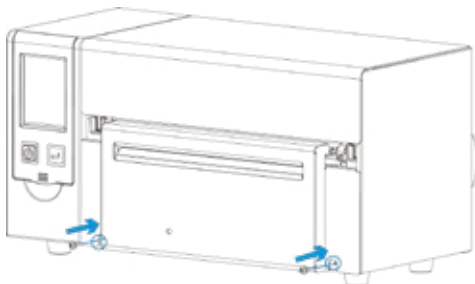

5.1 Print Line Adjustment

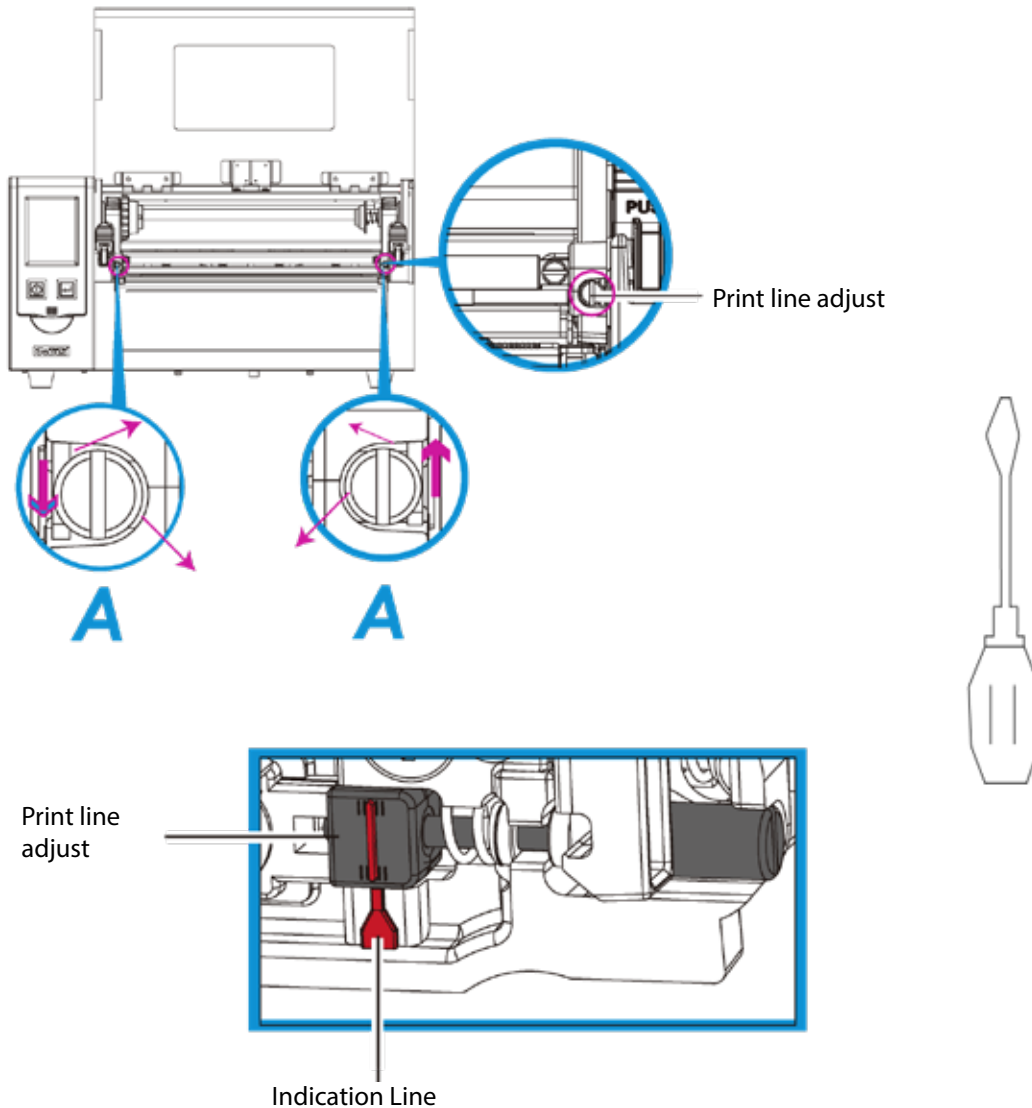

To have good print quality in hardness or thicker media, we will suggest to move the print line a little bit forward (paper feeding direction). Turn the flat screw driver (as above figure) in clockwise or counter clockwise to rotate the screws (A) to move back or forward the TPH position. The adjustment screw (A) of the left and right side of the print head position adjustment should be adjusted so that the print line is parallel to the center line of the roller. Adjust the screw (A) to rotate one turn, the print head displacement stroke is 0.5mm, it is recommended to adjust the way progressive, each time to adjust the 1/4 turn to confirm the print quality situation. (A) Turn the adjustment screw (A) on the left and right sides to the position where the adjustment line is aligned with the indicating line, and return to the original position and then adjust it again according to the above adjustment method.

5.2 Ribbon Tension Adjustment

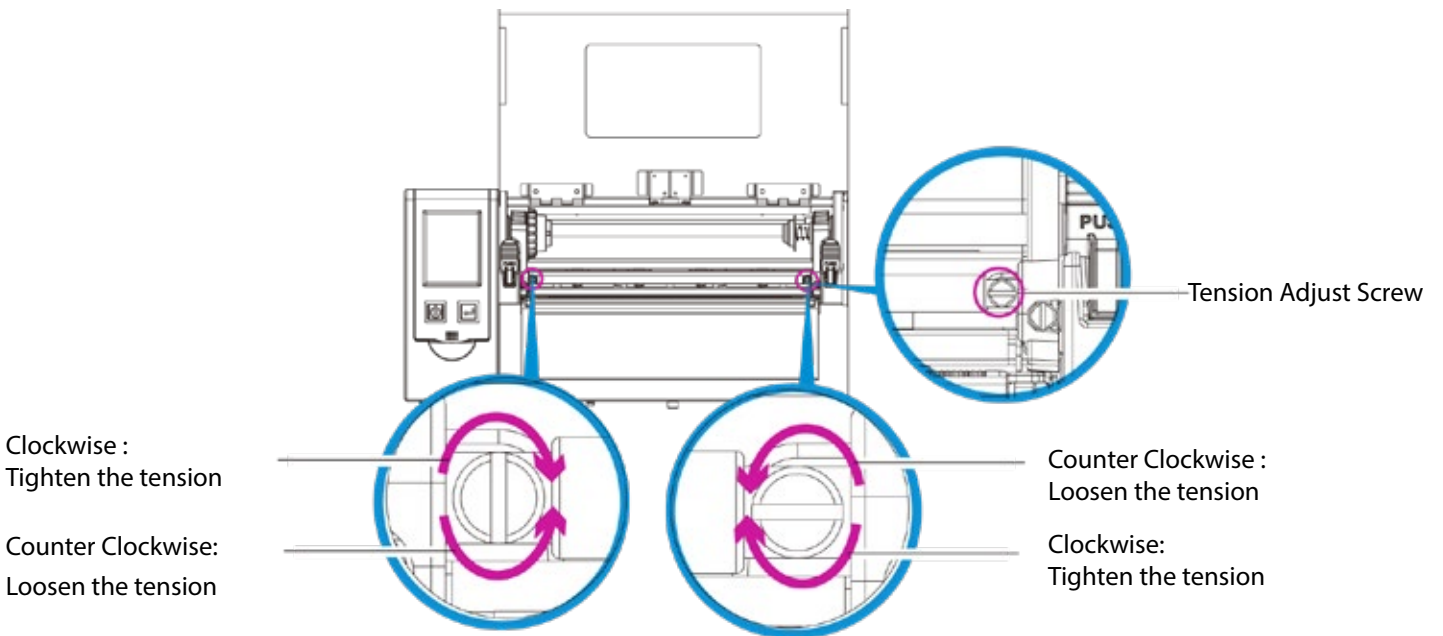

5.3 Print Head Cleaning

Dirt on the print head or ribbon, or glue residue from the label stock may result in inadequate print quality. The printer cover must therefore always be closed during printing. Keeping dirt and dust away from the paper or labels ensures a good print quality and a longer lifespan of the print head.

Switch the printer off to clean the printhead. To remove any label residue or other dirt from the print head, use a soft lint-free cloth dipped in alcohol.

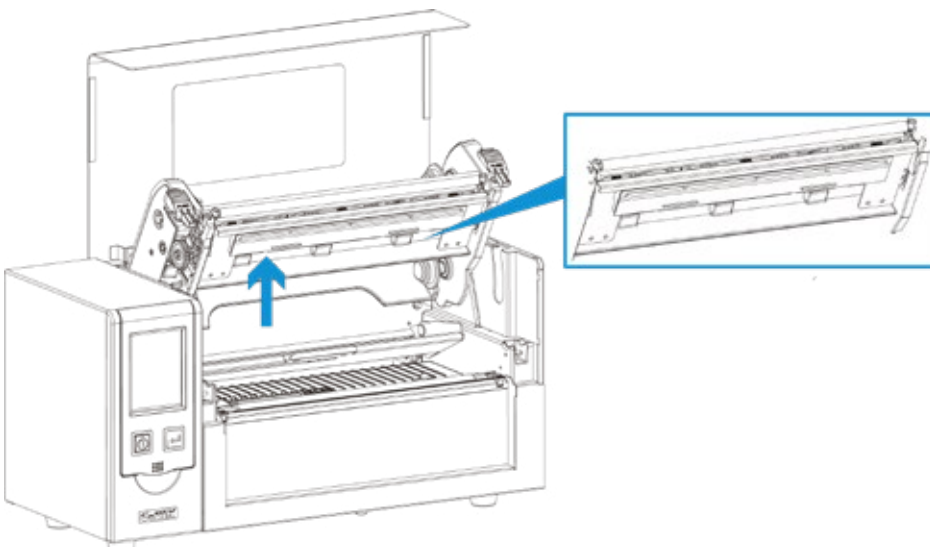

5.4 Print Head Pressure Adjustment

When printing on special media (with varying material thickness), the print quality may suffer. You will then need to adjust the print head pressure.

Use a screw driver and slowly turn the adjustment screws for the print head to increase or reduce the print head pressure.

Turn towards + (Plus): The pressure is increased

Turn towards - (Minus): The pressure is reduced

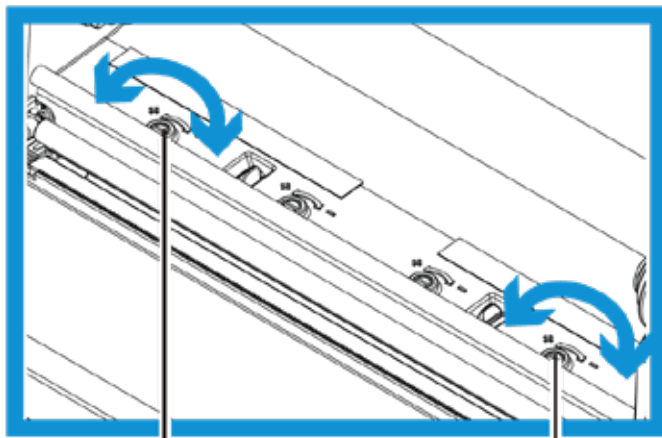

SCREW (LEFT)
Screw for adjusting
the print head
pressure on left side

SCREW (RIGHT)
Screw for adjusting
the print head
pressure on right side

5.5 Ribbon Wrinkle Adjustment

The use of different ribbon materials may cause wrinkling of the ribbon, which in turn affects the print result as illustrated by the examples in (a) and (b). To change the print quality, you can adjust the adjustment screws like shown on Section 5.4.



5.6 Cutter Error

While using the cutter, paper jams may occur. Please follow the below steps to clean the paper jam.

A socket head screw for adjusting the cutter is located on the bottom of cutter module, as shown in below illustration.

Switch off the printer. Use a screwdriver to turn the socket head screw and release the knife.

When you have cleared the paper jam, switch on the printer again. The cutter will automatically reset.

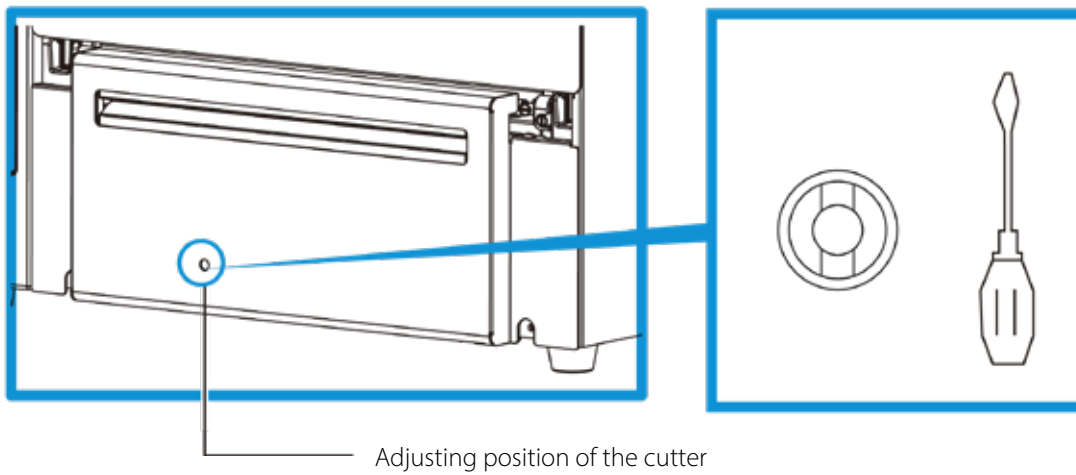

NOTE: Labels should be at least 30 mm high to ensure correct functioning of the cutter.

5.7 Troubleshooting

Problem	Solution
The printer is switched on but the display does not light up.	<ul style="list-style-type: none"> ▶ Check the power supply.
One or both LEDs light up red and printing is interrupted.	<ul style="list-style-type: none"> ▶ Check the software settings (driver settings) or command codes. ▶ Look for the error alert in the table in Section 3-3 Error alerts . ▶ Check whether the cutter is functioning normally and whether it is cutting at all. (Only if a cutter is installed.)
The label stock passes through the printer but no image is printed.	<ul style="list-style-type: none"> ▶ Please make sure that the label stock is loaded the right way up and that it is suitable material. ▶ Please make sure that the ribbon is loaded correctly.
The label stock jams during printing.	<ul style="list-style-type: none"> ▶ Clear the paper jam. Remove any label material left on the thermal print head and clean the print head using a soft lint-free cloth dipped in alcohol.
There is no printed image on part of the label or the image is blurred	<ul style="list-style-type: none"> ▶ Check the thermal print head for dust or other dirt (label material or ribbon residue). ▶ Check for errors in the application software. ▶ Check the ribbon for wrinkles. ▶ Check the power supply. ▶ Run a self test (Section 3-2) and check the test print pattern to see whether the print head prints over the entire width of the medium. ▶ Check the quality of the print medium.
The printed image is positioned incorrectly or a label is missed out during printing.	<ul style="list-style-type: none"> ▶ Run the Label size calibration function. (Section 3-2) ▶ Check the label height setting. ▶ Check whether there is paper or dust covering the sensor. ▶ Check the paper guide settings.
The cutter does not cut off the labels in a straight line.	<ul style="list-style-type: none"> ▶ Check whether the label stock is positioned straight.
The cutter does not cut off the labels completely.	<ul style="list-style-type: none"> ▶ Check whether the label is more than 0.2 mm thick.
When using the cutter, the labels are not fed through or cut off incorrectly.	<ul style="list-style-type: none"> ▶ Check whether the cutter has been correctly installed. ▶ Check whether the paper guides are functioning correctly.
The label dispenser is not functioning normally.	<ul style="list-style-type: none"> ▶ Check whether there is dust on the label dispenser. ▶ Check whether the label stock is positioned correctly.

Appendix

Model Name		FX810e
Print Method		Thermal Transfer/ Direct Thermal
Resolution		300 dpi (12 dot/mm)
Print Speed		up to 4 ips
Print Width		8.64" (219.5 mm)
Print Length		Min.1" (25.4 mm)**; Max .40" (1,016 mm)
Processor		32-bit RISC CPU
Memory	Flash SDRAM	128 MB Flash (60 MB for user storage) 32 MB
Sensor Type		Adjustable relective sensor and transmissive sensor , central aligned
Media	Type Width Thickness Label roll diameter Core diameter	Continuous from, gap labels, black mark sensing; label length set by auto sensing or programming Tear : Min. 4" (108 mm) - Max. 10" (255 mm) Cutter : Max. 9.05" (230 mm) Min. 0.002" (0.06 mm) - Max. 0.01" (0.25 mm) External Label stand :10" Max. (Standard Accessories included) Min. 1.5" (38.1 mm) - Max. 3" (76.2 mm)
Ribbon	Types Length Width Ribbon roll diameter Core diameter	Wax, wax/resin, resin Max. 981" (300 m) Min. 4.3" (110 mm) - Max. 8.66" (220 mm) 2.67" (68 mm) Max. 1" (25.4 mm)
Printer Language		EZPL, GEPL, GZPL auto switch
Software		NiceLabel Free 2019 DTM Edition
Resident Fonts		6, 8, 10, 12, 14, 18, 24, 30, 16X26 and OCR A & B Bitmap fonts 90°, 180°, 270° rotatable, single characters 90°, 180°, 270° rotatable Bitmap fonts 8 times expandable in horizontal and vertical directions TTF Fonts (Bold / Italic / Underline). 0°,90°, 180°, 270° rotatable
Download Fonts		Bitmap Fonts: 90°, 180°, 270° rotatable, single characters 90°, 180°, 270° rotatable Asian Fonts: 16x16, 24x24. Traditional Chinese (BIG-5), Simplified Chinese(GB2312), Japanese (S-JIS), Korean (KS-X1001) 90°, 180°, 270° rotatable and 8 times expandable in horizontal and vertical directions TTF Fonts: TTF Fonts (Bold / Italic / Underline). 0°,90°, 180°, 270° rotatable
Barcodes		1-D Bar Codes: China Postal Code, Codabar, Code 11, Code 32,Code 39, Code 93, Code 128 (subset A, B, C), EAN-8, EAN-13, EAN 8/13 (with 2 & 5 digits extension), EAN 128, FIM, German Post Code, GS1 DataBar, HIBC, Industrial 2 of 5 , Interleaved 2-of-5 (I 2 of 5), Interleaved 2- o-f 5 with Shipping Bearer Bars, ISBT – 128, ITF 14, Japanese Postnet, Logmars, MSI, Postnet, Plessey, Planet 11 & 13 digit, RPS 128, Random Weight, Standard 2 of 5, Telepen, UPC-A, UPC-E, UPC-A and UPC-E with EAN 2 or 5 digit extension, UCC 128, UCC/EAN-128 K-Mart 2-D Bar Codes : Aztec code, Code 49,Codablock F , Datamatrix code, MaxiCode, Micro PDF417, Micro QR code, PDF417,QR code, TLC 39

Code Pages	Codepage 437, 737,850, 851, 852, 855, 857, 860, 861, 862, 863, 865, 866, 869, Windows 1250, 1251, 1252, 1253, 1254, 1255, 1257 Unicode UTF8, UTF16BE, UTF16LE
Graphics	Resident graphic file types are BMP and PCX, other graphic formats are downloadable from the software
Interfaces	USB 2.0 (B-Type) Serial port: RS-232 (DB-9) IEEE 802.3 10/100 Base-Tx Ethernet port (RJ-45) USB Host (A-Type)
Control Panel	Backlight 3.2" touch screen LCD 1 Power on/standby button with dual colour LED backlight 1 FEED / PAUSE / CANCEL button with dual colour LED : Ready (Green); Error (Red) 1 Calibration button at rear panel
Power	100-240V AC, 50/60 Hz 140 watts, standby 9,6 watts
Real Time Clock	Standard
Environment	Operation temperature :41°F to 104°F (5°C to 40°C) Storage temperature: -4°F to 140°F (-20°C to 60°C)
Humidity	Operation: 20-85%, non-condensing Storage: 10-90%, non-condensing
Agency Approvals	CE (EMC),FCC Class B,CB,UL,cUL,CCC
Dimension	Length 221 mm Height 224 mm Width 431 mm
Weight	12.5 kg, excluding consumables
Options	Cutter, Parallel port adaptor module (Centronic female 36-pin) (Dealer Install) Bluetooth (Dealer Install) Wireless LAN (IEEE 802.11 b/g/n) (Dealer Install)

NOTE

*Specifications are subject to change without notice. All company and/or product names are trademarks and/or registered trademarks of their respective owners.

**Minimum print height and maximum print speed specification compliance can be dependent on non-standard material variables such as label type, thickness, spacing, liner construction, etc. GoDEX is pleased to test non-standard materials for minimum print height, and maximum print speed capability.



DTM Print GmbH
Mainzer Strasse 131
65187 Wiesbaden
Germany
support@dtm-print.eu
dtm-print.eu

